

NOV 23 1920

PROPERTY OF M.I.G.A. THE

RADIO REVIEW

A MONTHLY RECORD OF SCIENTIFIC
PROGRESS IN RADIOTELEGRAPHY
AND TELEPHONY

VOL. I

NOVEMBER, 1920

No. 14

Editor :

PROFESSOR G. W. O. HOWE, D.Sc., M.I.E.E.

Assistant Editor:

PHILIP R. COURSEY, B.Sc., A.M.I.E.E.

CONTENTS.

Recent Commercial Developments in Wireless
Major H. MACCALLUM

Critique of Capt. Robinson's Article "A Method of Direction Finding" Major C. E. PRINCE, O.B.E.

A Theory of the Amplitude of Free and Forced Triode Vibrations BALTH. van der POL, Jun., D.Sc.

The Capacity of Rectangular Plates and a Suggested Formula for the Capacity of Aerials. THE EDITOR

Multiplex Telephony and Telegraphy using High Frequency Currents (Wired Wireless) K. W. WAGNER

Review of Radio Literature :
Abstracts of Articles and Patents
Book Reviews

Correspondence

Two Shillings and Sixpence Net

THE RADIO REVIEW

VOL. I

NOVEMBER, 1920

NO. 14

Recent Commercial Developments in Wireless.

By Major H. MACCALLUM.

The remarkable technical progress which has taken place during the last few years has resulted in the development of a number of new commercial types of apparatus, some representative examples of which it is the purpose of the present article to describe.

The three-electrode valve of the "hard" or high vacuum type, perfected during the war, has formed the basis of a number of new patterns of transmitter. Standard continuous wave telegraph sets of from 100 watts up to 25 kW, in which the three-electrode valve is the source of high frequency energy, are commercially available at the present time, and installations of higher powers are in course of erection at commercial wireless stations. Standard wireless telephone sets up to 6 kW are also obtainable, and installations rated at from 15 to 25 kW have passed through prolonged tests under actual working conditions, with entirely satisfactory results.

In the smaller sets it is usual to combine the telephone and telegraph equipment, the source of high frequency energy being common to both, and the whole apparatus with the exception of the motor generator and main switches is conveniently mounted in a wooden cabinet, together with the receiving gear. An example of this type of construction will be found in the $1\frac{1}{2}$ kW cabinet set described later. Smaller sets are arranged for mounting in vehicles or for transport by pack animals, and the special conditions on aircraft are met by the provision of extremely light and compact apparatus obtaining its energy from a wind driven generator and operated by a remote control unit, which allows the transmitting and receiving gear to be housed in a convenient and suitable position, while the key, microphone, telephones, switches, etc., are easily accessible to the operator. Larger installations are usually built up on the panel or switchboard principle, and arranged in such a manner that the continuous wave transmitter is a complete unit, which can be adapted to telephony by the addition of an extra control panel carrying the modulating and control valves, together with certain refinements unnecessary in the case of telegraphy. The 6 kW installation described later is an example of the type referred to.

In the Mercantile Marine the necessity for an installation which is primarily suitable for use in connection with safety of life at sea, has resulted in the production of a combined "spark" and C.W. transmitter, by means of

which S.O.S. calls can be sent out on "spark" while long distance communication is handled on continuous waves.

Early this year the ex-German liner *Imperator* was fitted with C.W. and "spark" by way of experiment, the apparatus being of a pattern not specially designed for installation on board ship. The results obtained were of such an encouraging and satisfactory nature that a number of other liners were fitted and a new set was specially designed to meet the demand. Simplified diagrams of connections of this set are shown in Figs. 1 and 2, and its general appearance is indicated in the photographs, Figs. 3 and 4.

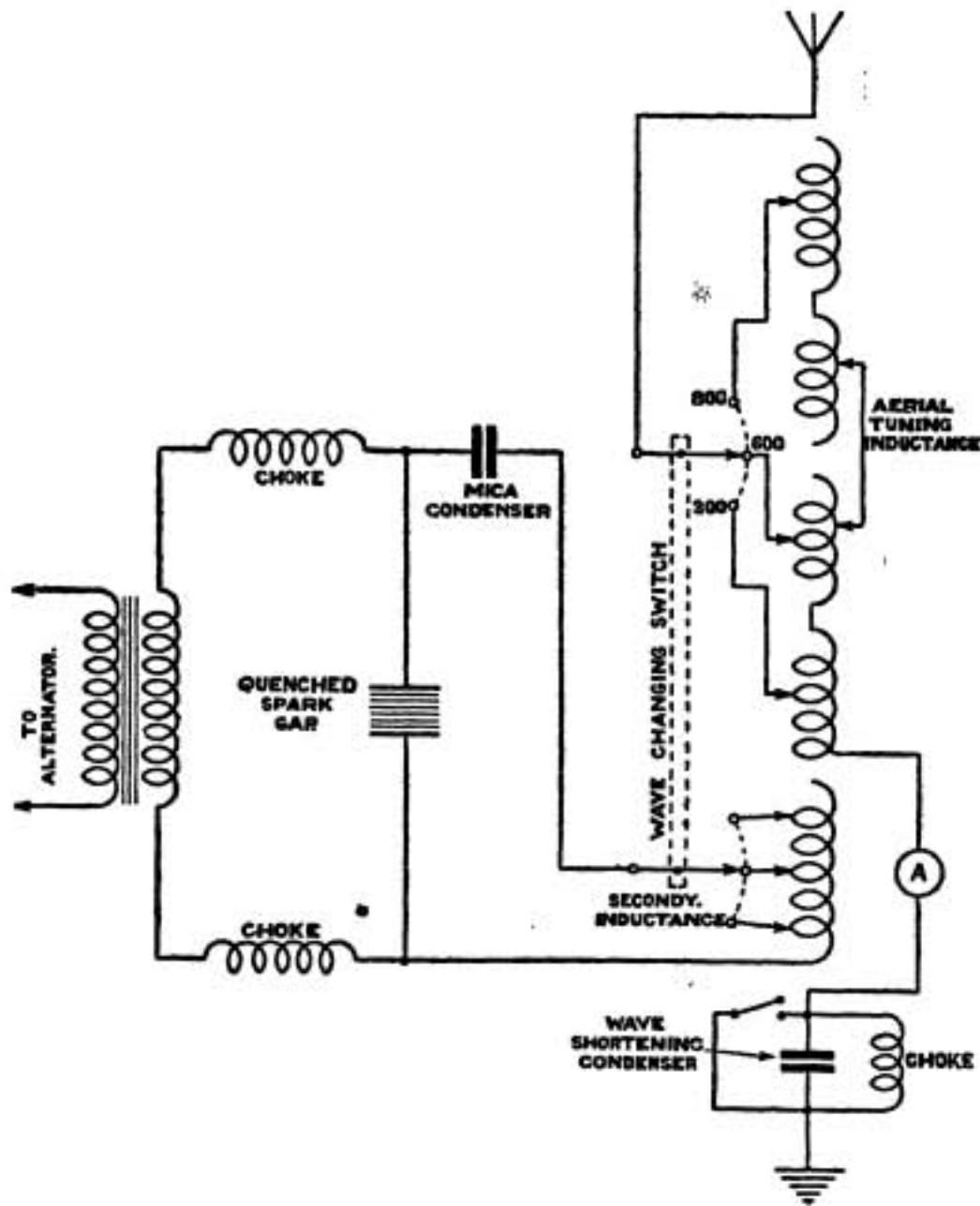

FIG. 1.—CONNECTIONS OF 1½ kW SHIP SET (SPARK CIRCUITS).

The aerial, earth connections and manipulating key are common to the two transmitters both of which derive their power from the same 500 cycle motor alternator with step-up transformer.

Arrangements are provided for working the set at reduced power in order to minimise interference when communicating short distances. This is effected on the C.W. transmitter by means of a power regulating choke with a sliding core which is connected in series with the primary of the power

transformer. When the "spark" transmitter is in use, this choke is short circuited and reduction of power if required is obtained by cutting out one or more of the spark gaps.

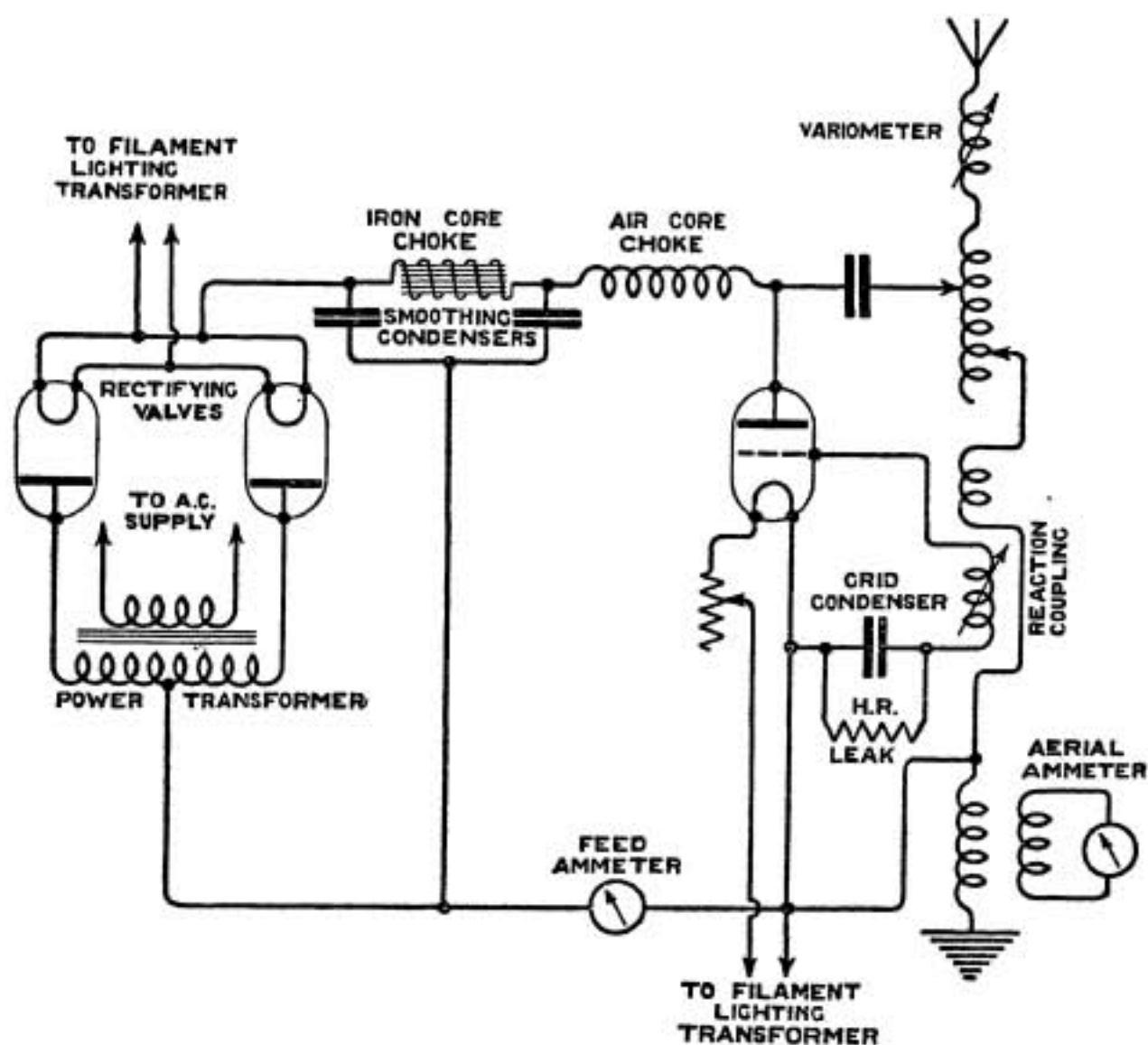

FIG. 2.—CONNECTIONS OF 1½ kW SHIP SET (C.W. CIRCUITS).

The change-over from one system to the other is effected by means of two switches. The first connects the power transformer secondary to the "spark" or C.W. transmitter, as desired, making the necessary connection to the middle point of the secondary winding in the latter case, and also connects the two primary windings of the transformer in parallel for C.W. working or in series for "spark" working.

The spark transmitter is designed to transmit on all wavelengths between 220 and 800 metres, the normal adjustments being for 450, 600 and 800 metres.

The three-way wave-changing switch which can be clearly seen in Fig. 3 controls both the primary and secondary circuits and enables a quick change to be made from any one of the three selected wavelengths to any other.

The inductance windings are of a patented flat spiral type, consisting of a double strip of copper bedded into the surface of an ebonite panel. Tappings can be made to any point of the spiral by means of special plugs which fit into the space between the two strips.

The quenched gap is of the standard Marconi pattern illustrated in Fig. 5.

In this set space is saved by the employment of mica condensers in place of the more bulky glass and oil insulated pattern. These are contained in cast metal containers fitted with terminal covers of insulating material. The wave-shortening condenser, in the aerial circuit Fig. 1, is of the same type as that of the primary unit, differing only in capacity. When not required this condenser can be short circuited by means of a switch provided for the purpose.

The correct syntonisation of the primary and secondary circuits is indicated by means of an aerial ammeter of the transformer type.

The continuous wave transmitter is of the auto-coupled type. The circuits and valves are mounted on a panel (Fig. 4) approximating in size to that of the spark set.

The 500 cycle high tension alternating current supplied by the secondary winding of the transformer (Fig. 2) is rectified to a unidirectional pulsating current by means of rectifying valves of the M.R. 1 pattern (Fig. 6) operating on the familiar principle of the Fleming valve. By the use of two such rectifying valves and a centre connection from the transformer secondary winding a pulsating current of frequency equal to double the initial frequency is produced. Pulsations or ripples are smoothed out by a condenser of $0.25 \mu\text{F}$ capacity which is shunted with a large iron cored choking coil.

The oscillator (Fig. 7) is a single three-electrode valve of the M.T. 4 pattern, the anode of which is fed by the smoothed-out, rectified, alternating current, through an air cored choking coil the function of which is to obstruct the return of high frequency currents to the supply circuit. The negative connection to the filament is through a milliammeter which indicates the H.T. feed current to the valve.

The grid of the power valve is connected through a reaction coil and condenser, shunted by a high resistance leak, to the secondary of the power valve filament lighting transformer and to earth. The reaction coil is electromagnetically coupled to the aerial tuning inductance.

The filaments of the two rectifying valves and the power valve are lighted from a small step-down transformer, the primary winding of which is connected to the slip rings of the rotary converter through two choke coils provided with adjustable iron cores. One of the chokes is used for adjusting the brilliancy of all three valve filaments by alteration to the primary voltage of the transformer. The power valve filament current is also adjustable independently of the rectifiers by means of a sliding resistance.

The function of the other choke, termed the compensating choke, is to prevent fluctuation in the brilliancy of the valves due to the drop in voltage which occurs when current is taken from the power transformer in the act of sending Morse signals. This choke is in series with the lighting transformer primary winding so long as the sending key is up, but is short circuited through a pair of subsidiary contacts when it is depressed. A second pair of contacts disconnects the grid condenser leak when the key is up and the main contacts make and break the primary of the power transformer thus controlling the high tension feed to the anode of the power valve.

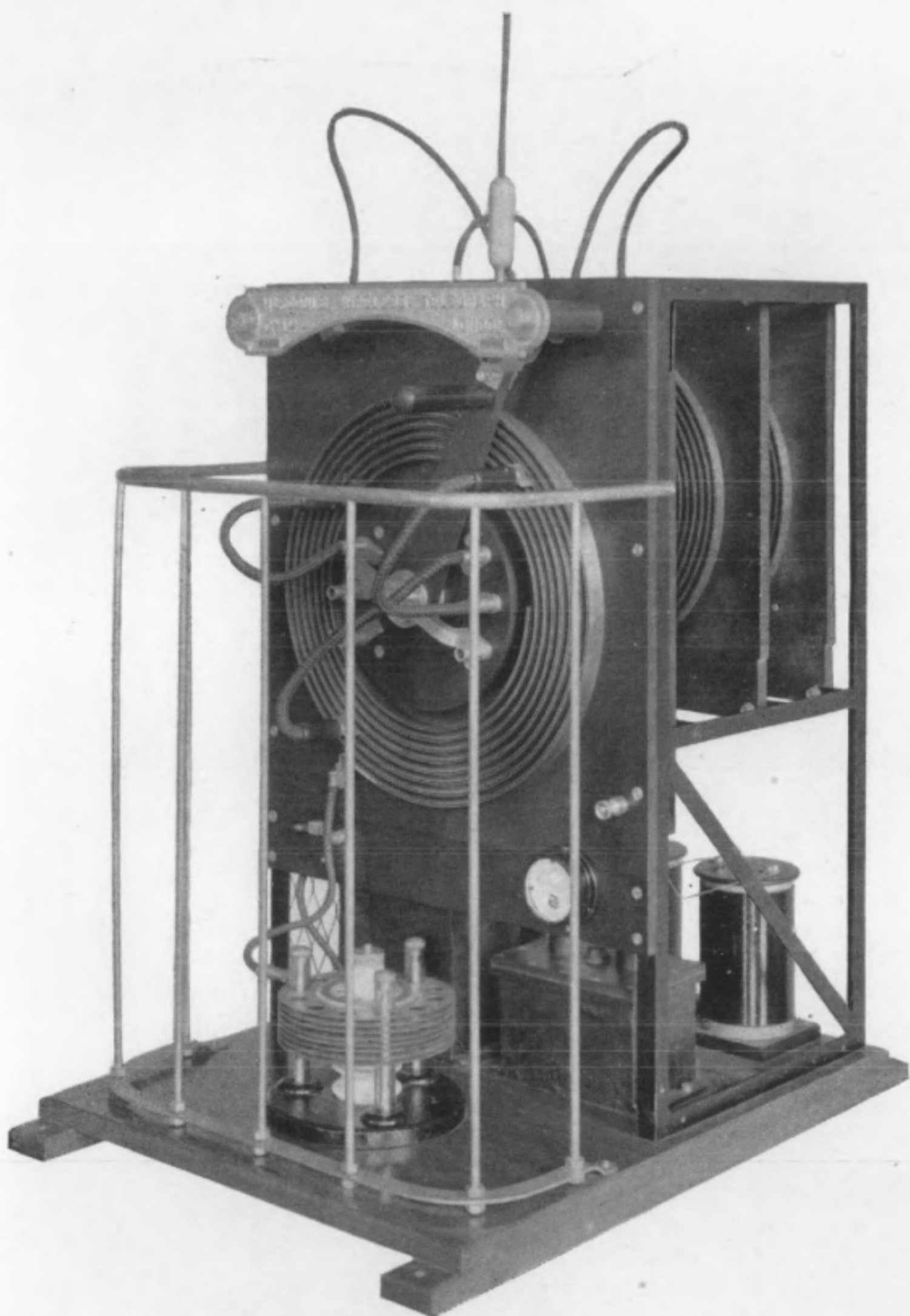

FIG. 3.— $1\frac{1}{2}$ kW SHIP SET SPARK TRANSMITTER.

(To face p. 688.)

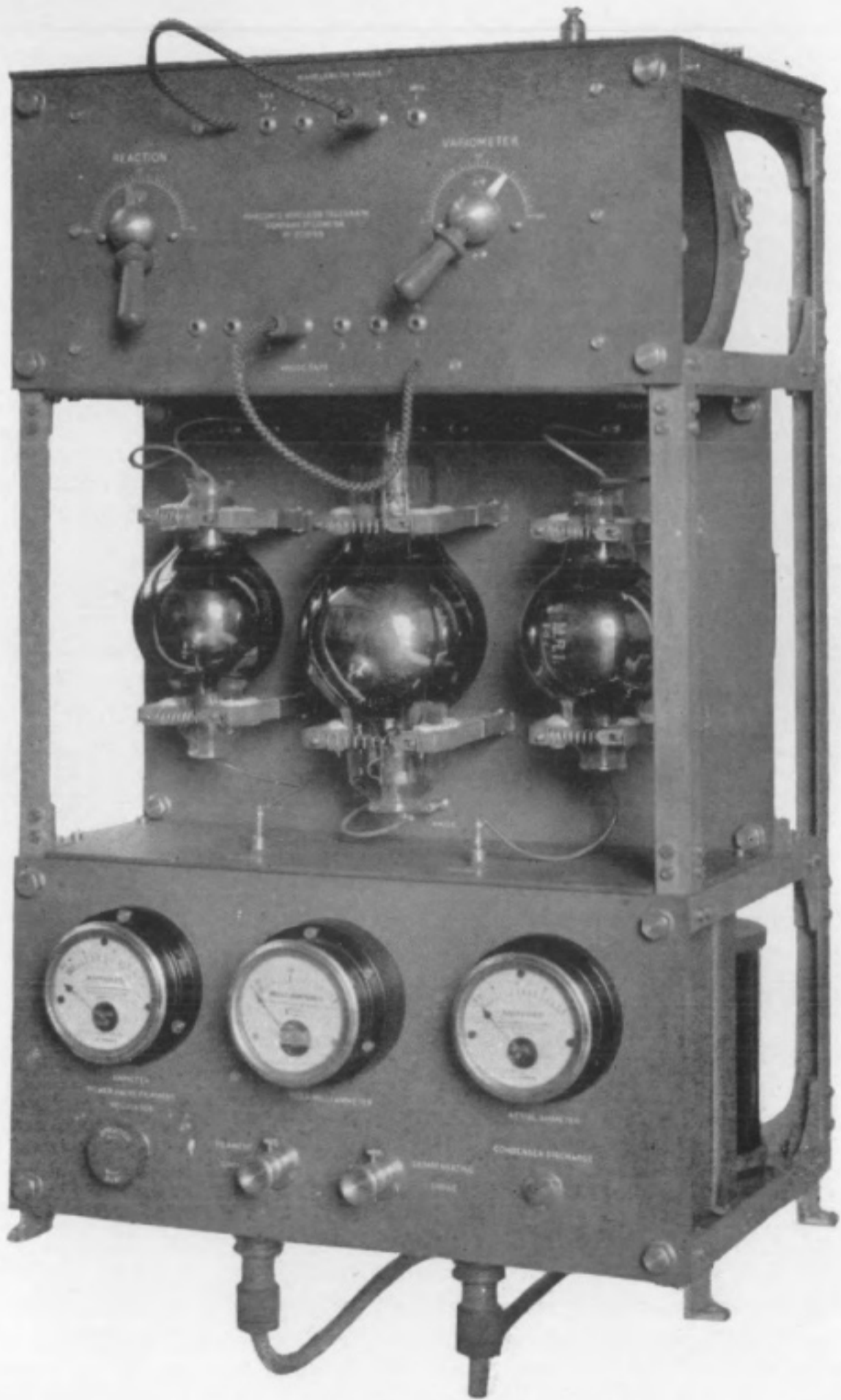

FIG. 4.—1½ kW SHIP SET C.W. TRANSMITTER.

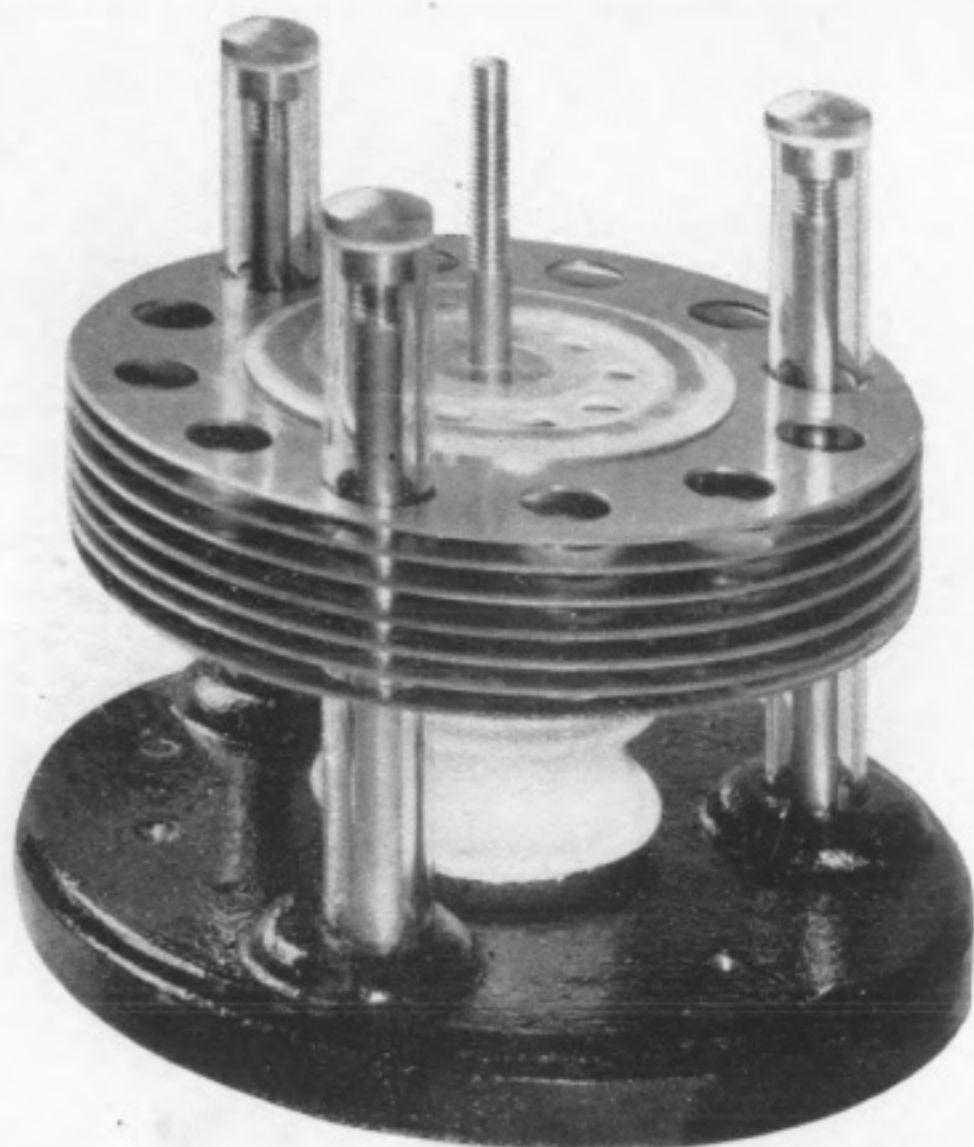

FIG. 5.—STANDARD MARCONI QUENCHED GAP (PARTLY ASSEMBLED).

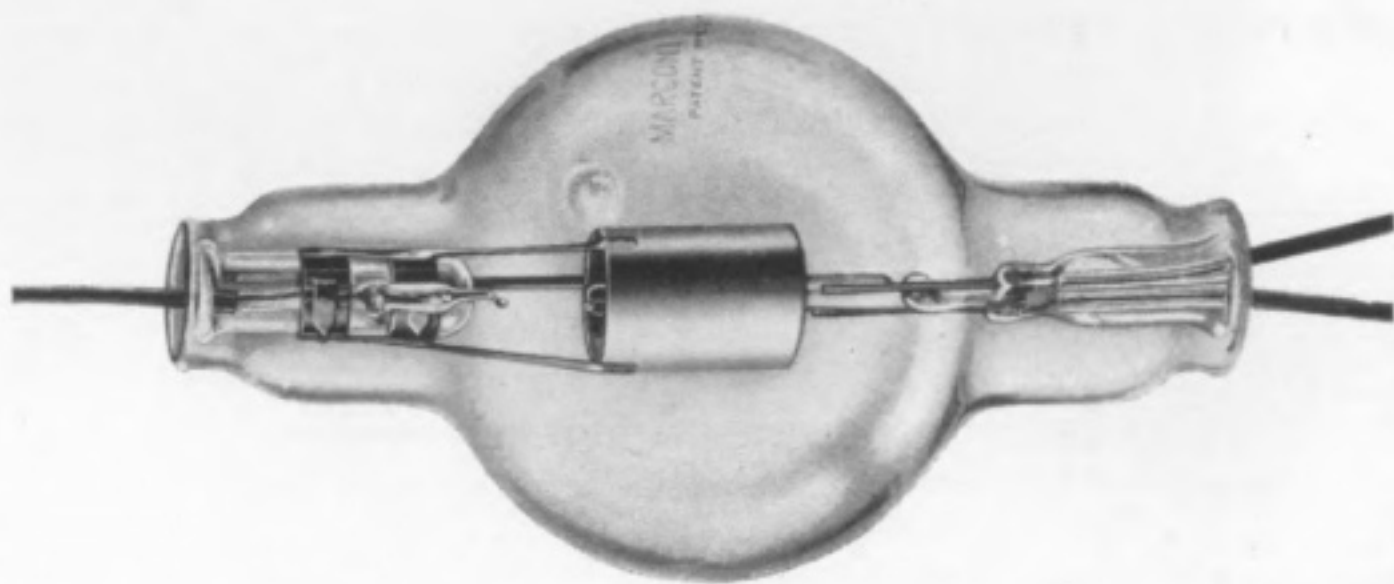

FIG. 6.—M.R. 1 RECTIFYING VALVE.

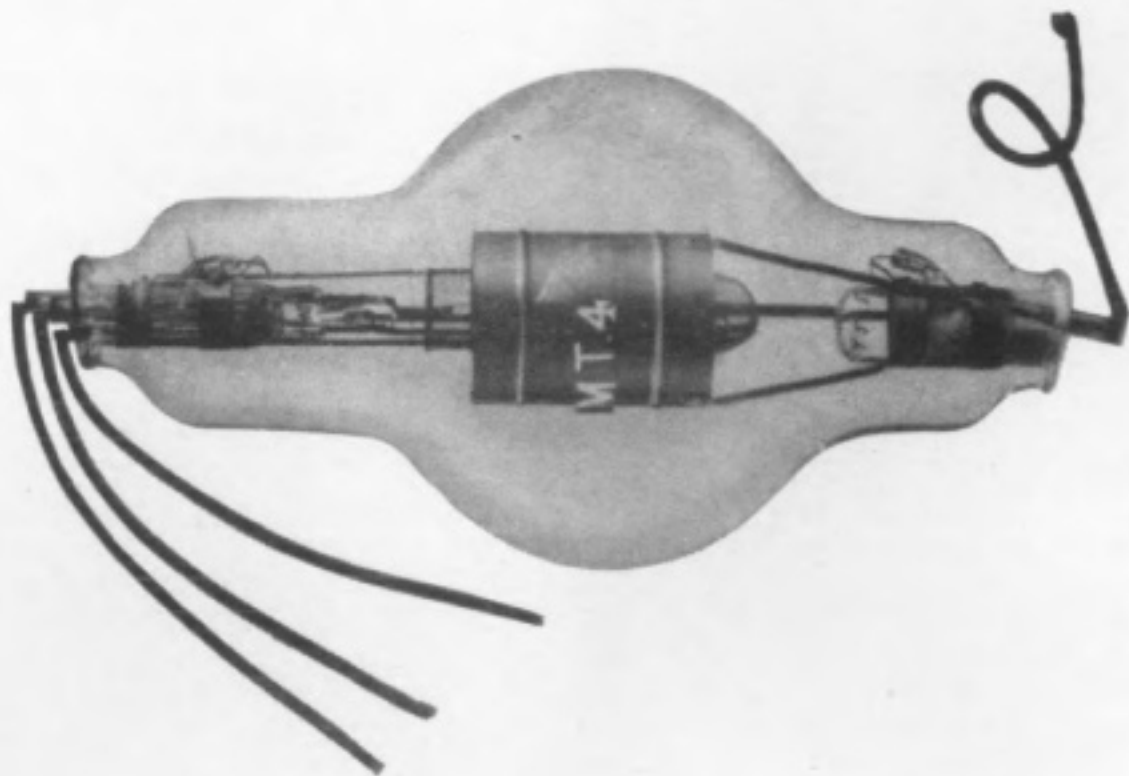

FIG. 7.—M.T. 4 TRANSMITTING VALVE.



FIG. 8.— $1\frac{1}{2}$ kW CABINET SET FOR TELEGRAPHY AND TELEPHONY.

(To face p. 689.)

A $1\frac{1}{2}$ kW combined telegraph and telephone set of the cabinet type is illustrated in Fig. 8, and Fig. 9 is a simplified diagram of the transmitting circuits.

Referring to Fig. 8, the rectifying, control and power valves are mounted on a recessed panel of insulating material at the left of the cabinet. The receiving apparatus is on the right, and the transmitting aerial tuning inductance and reaction coil are supported on insulators at the top of the cabinet. The aerial and feed ammeters are seen on the left hand and centre respectively, the "send-receive" change-over switch at the centre, and in front of this the two transmitting keys. The speaking microphone hangs inside the cabinet on the extreme right.

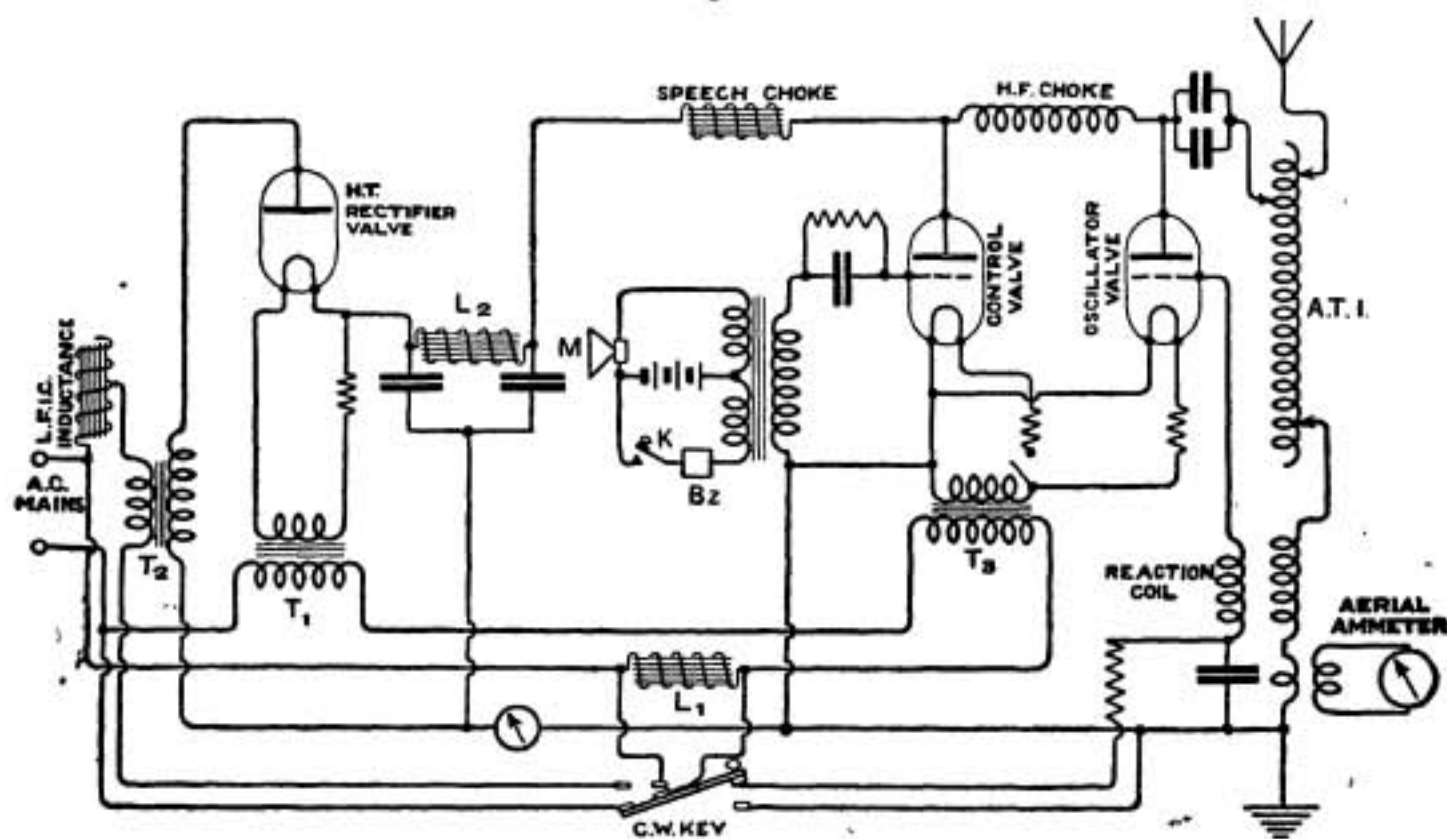

FIG. 9.— $1\frac{1}{2}$ kW CABINET SET, SIMPLIFIED DIAGRAM OF CONNECTIONS.

Bz = Buzzer; L_1 = Compensating Choke; T_1 and T_3 = Filament Transformers; M = Microphone; T_2 = Power Transformer; L_2 = Smoothing Choke; K = Tonic Train Key; A.T.I. = Aerial Tuning Inductance.

For continuous wave telegraphy a Morse key interrupts, at one and the same time, the reaction circuit and the "anode" supply circuit, thus throwing the valve in and out of action without change of wavelength. The Morse key is also fitted with contacts which are connected across a choke coil in the primary circuit of the filament lighting transformer, so that the filament current remains constant during transmission. The key carries a switch at one side; for continuous wave transmission the switch is thrown over to the left, for telephony and "tonic train" it is moved to the right.

For telephony the amplitude of the oscillations due to the first valve is controlled by a second valve of the same size and pattern, fitted on the left hand side of the large valve panel. This valve has in its "grid" circuit the secondary of an audio-frequency transformer, the primary of which is wound in two halves, one half being connected to a microphone, the other to a high note buzzer and a Morse key. A six volt accumulator battery

is common to both circuits. The high note buzzer and key are provided for use when it is desired to communicate by the "tonic train" method with stations which are not equipped for the reception of C.W. signals.

The anodes of the oscillator and control valves are fed with high tension direct current, which is obtained from the secondary winding of a step-up transformer by means of an M.R. 1 rectifying valve in circuit with a suitable smoothing-out choke. Referring to Fig. 9 it will be seen that the feed current passes through an iron cored "speech choke," which, on account of its high inductance, allows of speech frequency potential variations at the valve anodes while the high tension supply potential remains practically constant. A step-down transformer supplies current to the filaments of the three valves. This transformer has two independent secondaries, one of which feeds the oscillator and control valves, and the other, which is specially insulated, supplies the rectifier.

The receiving circuits are arranged for the reception of continuous wave, phone, tonic train, or spark signals, over a wavelength range from approximately 300 to 3,000 metres. When sharp tuning is not required the receiver is connected as in Fig. 10, which represents the normal watching or "stand-by" circuit. A multiple contact switch is provided, by operating which a secondary circuit may be introduced, and the connections rearranged as in Fig. 11. Under these conditions the tuning is very much sharper and the liability to interference is correspondingly reduced.

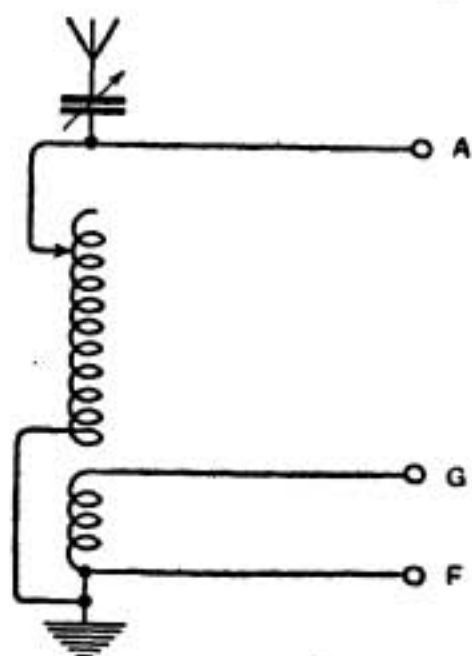

FIG. 10.—STAND-BY RECEPTION.

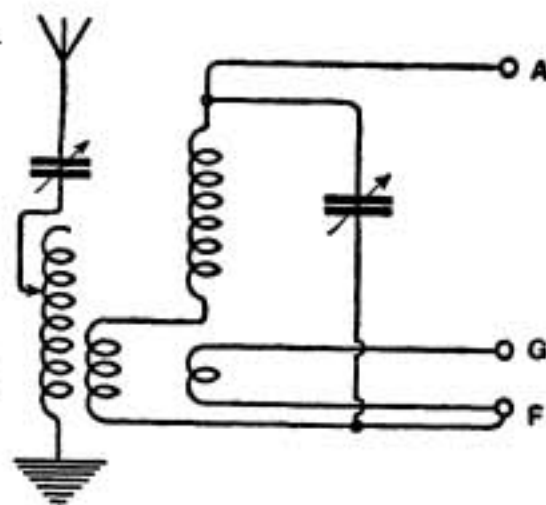

FIG. 11.—TUNED RECEPTION.

1½ kW CABINET SET, DIAGRAM OF TUNING CIRCUITS.

The terminals A G and F (Figs. 10 and 11) are connected to the corresponding terminals of a standard seven valve amplifying detector, which is incorporated in the receiving panel of the right hand side of the cabinet.

The change from transmission to reception or *vice versa* is effected instantaneously by a single movement of a multiple-contact change-over switch. The normal position of the switch handle is to the left, in which position the aerial is connected to the receiving tuner and the battery circuit

through the microphone broken, the set being in a condition for reception. On throwing the switch to the right, the aerial is put to earth through the aerial ammeter, the battery is connected to the microphone or buzzer, and the alternating current circuit is closed first through the lighting transformer, and then through the power transformer, thus placing the set in condition for transmission. When the switch is in the "receive" position, it will be noted that the transmitting gear is isolated from the supply, but it remains alive owing to the charge held by the smoothing-out condensers in the rectifier circuit. Provision is made for discharging these condensers by means of an ebonite press button, which is operated before live parts of the gear are handled.

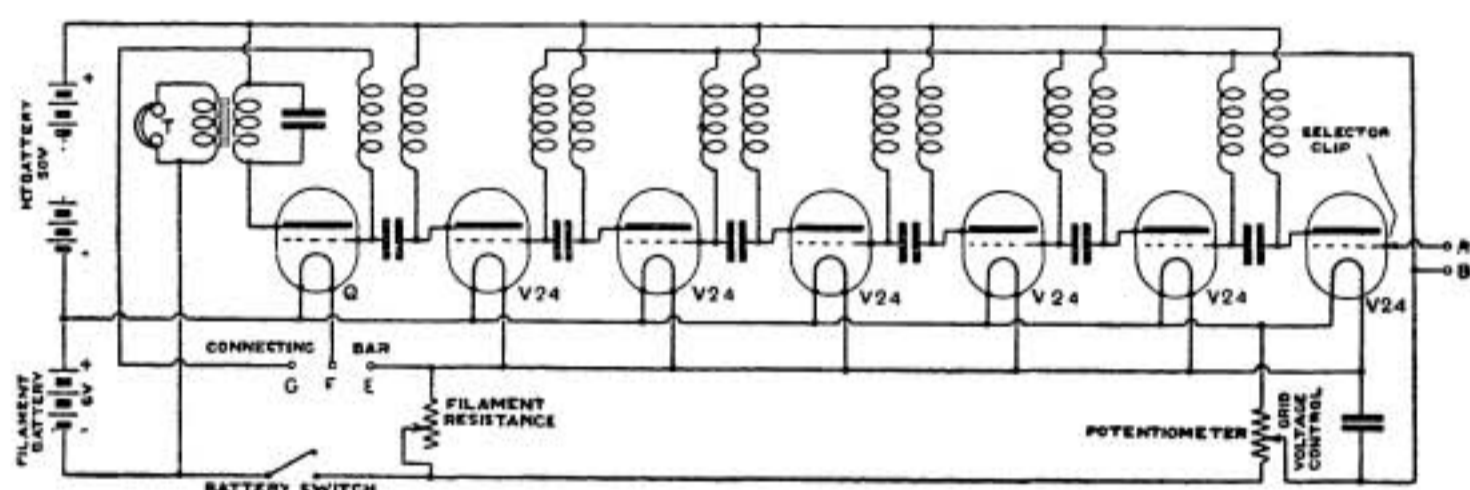

FIG. 12.—SIMPLIFIED DIAGRAM OF CONNECTIONS OF SEVEN VALVE AMPLIFYING DETECTOR.

The amplifying detector is of the aperiodic pattern, that is to say its resonance curve has no definite peak though the amplification value is not uniform over the whole range of wavelengths. Fig. 12 is a simplified diagram of connections, on referring to which it will be seen that there are six valves of the "V. 24" pattern and one "Q" valve connected in cascade. The grids of the first six valves, which are for high frequency amplification, are connected to the slider of the potentiometer across the filament lighting battery. The "Q" valve, which is for rectification, is designed to work at a definite potential and is connected, through its transformer, to the negative side of the filament.

The cascade connection referred to above is an arrangement whereby each successive valve increases the amplitude of the oscillation applied to it by a constant ratio, the resulting amplification following a geometrical progression. The incoming oscillations are led to the grid of the first valve, the plate circuit of which is connected *via* the primary of a specially designed transformer to the positive pole of the H.T. battery, and thence to the filament. The amplified oscillation from the plate circuit of one valve is transferred to the grid of the next by the use of two distinct principles, the combination of which increases the efficiency of the amplification. Firstly, there is the inductive coupling of the two windings of the transformer; secondly, owing to the high resistance of the coils, there is an appreciable voltage drop in the plate circuit when current is flowing, and by means of small condensers and also of the capacity between the windings themselves, variations of this

voltage drop, caused by incoming signals, are communicated to the grid of the next valve.

With most cascade arrangements there is a tendency for the valves to generate persistent oscillations, and if this occurs the amplification is greatly reduced. In the pattern here described, such a tendency can be checked by suitably adjusting the potentiometer.

The reaction coil in the tuner, Figs. 10 and 11, is connected to the terminals G and F of the amplifier from which the connecting bar is removed. If the reaction coupling is made sufficiently tight, the valves will be caused to generate high-frequency persistent oscillations, thereby rendering possible the "auto-beat" method of continuous wave reception. Also by carefully adjusting the reaction so that the valves are on the point of oscillation, the amplification of spark signals may be increased.

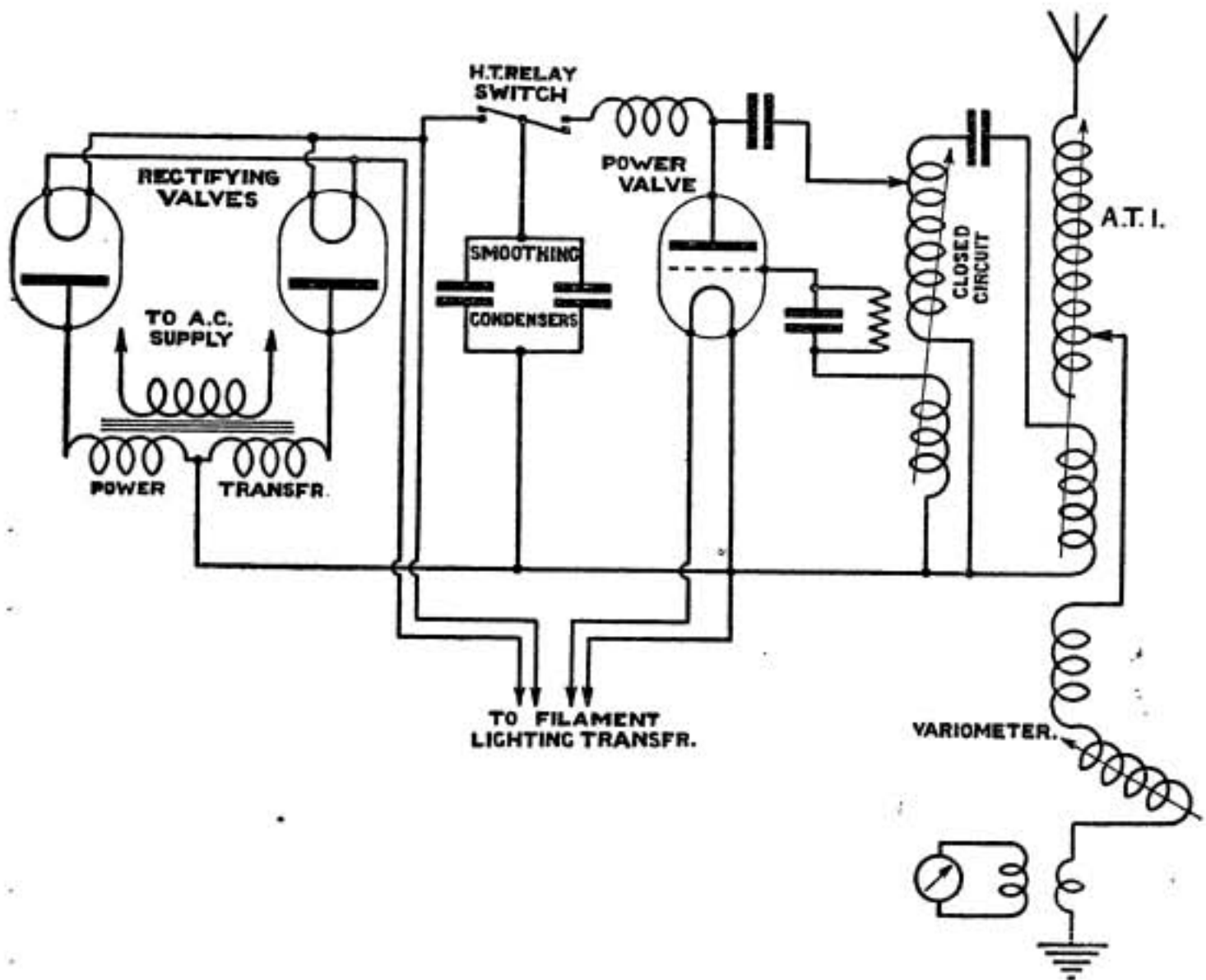

FIG. 14.—6 kW VALVE SET, SIMPLIFIED DIAGRAM OF CONNECTIONS FOR TELEGRAPHY.

As previously indicated valve transmitters of larger output are designed on the lines of a power switchboard, and in the case of the 6 kW set, with a description of which it is proposed to complete this brief survey of modern commercial developments, all the switches necessary for the operation of the set are controlled by electrically operated relays.

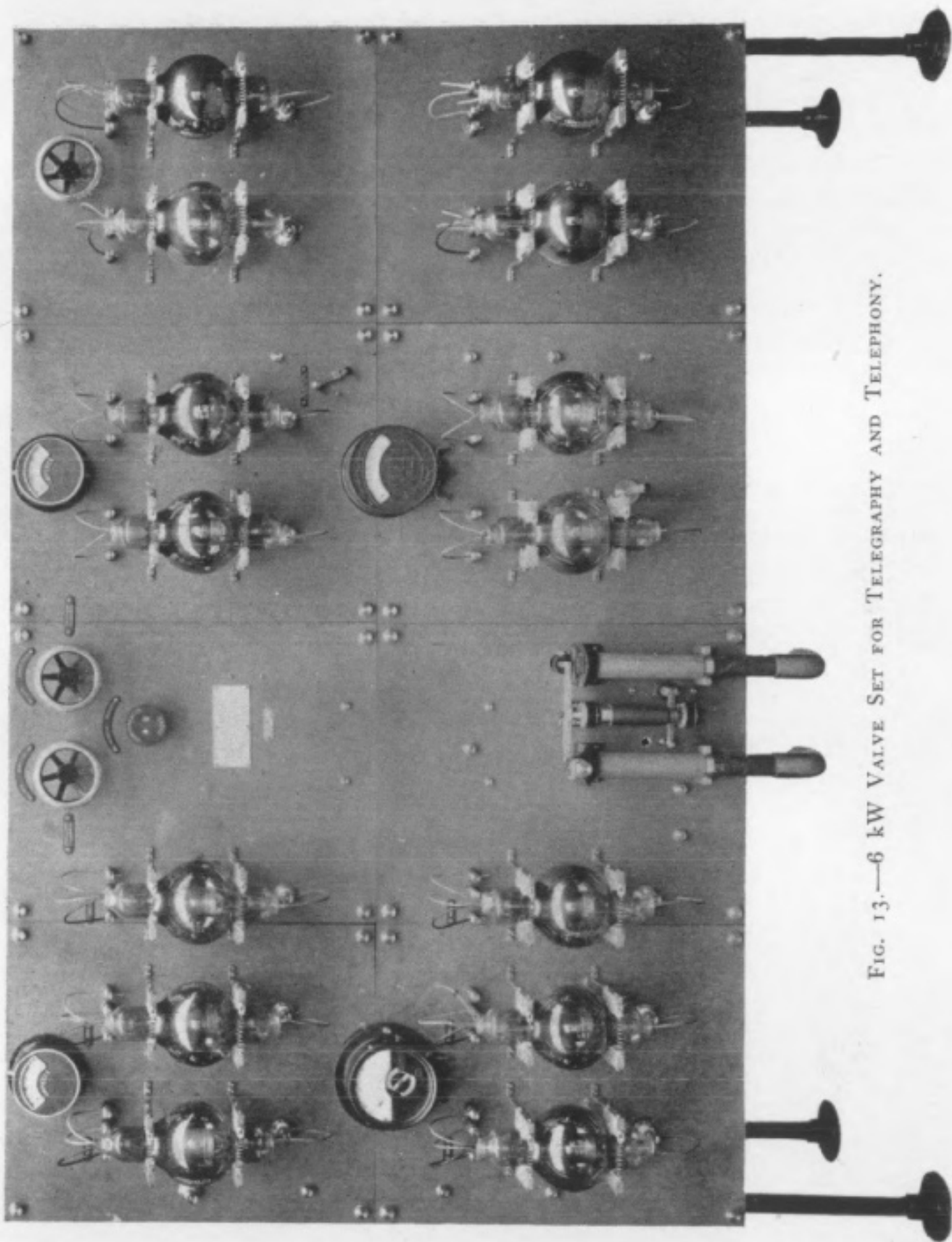

FIG. 13.—6 kW VALVE SET FOR TELEGRAPHY AND TELEPHONY.

(To face p. 692.)

The complete installation consists of the following :—

- (a) The panel on which are mounted the valves and relays with their circuits and accessories (see Fig. 13).
- (b) The aerial and closed circuit inductances with coupling and reaction coils, variometer and closed circuit condenser.
- (c) The power unit, consisting of a motor generator, wound to suit the available direct current voltage and generating alternating current at 500 volts 300 cycles.
- (d) The remote control unit, consisting of the manipulating key, the microphone and three switches.

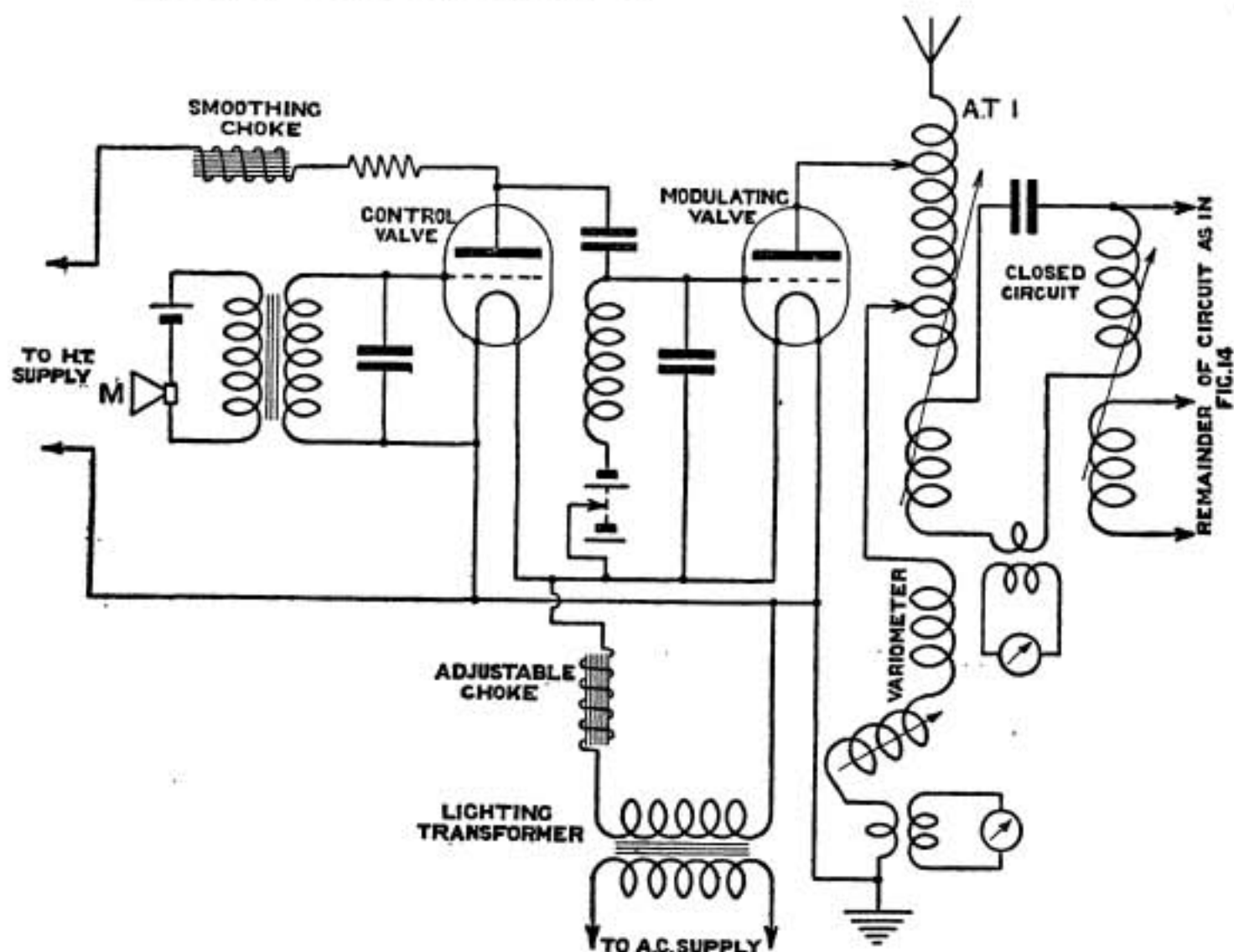

FIG. 15.—6 kW VALVE SET, SIMPLIFIED DIAGRAM OF CONNECTIONS FOR TELEPHONY.

Four rectifying valves of the type illustrated in Fig. 17 are used in providing the high tension supply for the valve anodes by the method previously described.

The standard equipment is designed for transmission on wavelengths from 2,000 to 4,000 metres, with an aerial of $0.003\mu\text{F}$ capacity, having a natural wavelength of 1,000 metres. With larger aerials correspondingly greater wavelengths are obtainable without loss of efficiency.

The essential features of the circuits are shown in the simplified diagrams in Figs. 14 and 15. The first illustrates the working of the set when used for telegraphy, while the second shows the circuit for telephony.

The switching arrangements and relays by which the change over from telegraphy to telephony is effected, are shown in a more detailed diagram (Fig. 16).

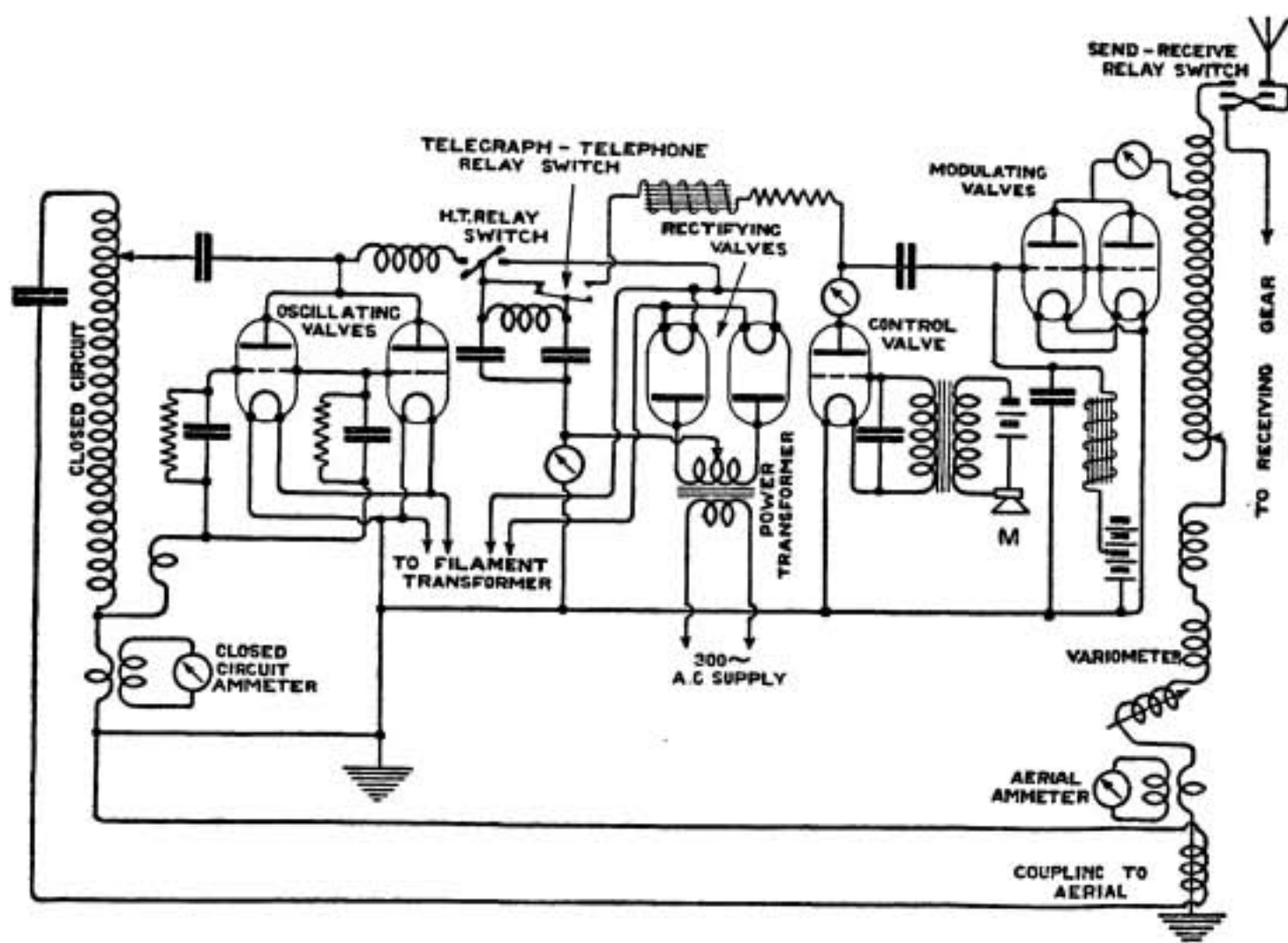

FIG. 16.—6 kW VALVE SET, DETAILED DIAGRAM OF CONNECTIONS.

The aerial circuit is loosely coupled to a closed oscillation circuit, consisting of an inductance and a condenser, which derives energy from a bank of 6 three-electrode valves of the type illustrated in Fig. 7. For the sake of simplicity only one valve is shown in Fig. 14. The common grid circuits of these valves are coupled back to the main circuit, so that continuous oscillations are produced when the power is applied.

Transmission of telegraphic signals is effected by means of a Morse key controlling a relay switch in the high-tension supply circuit, the spark at the contacts being quenched by an air blast from a motor-driven blower. A second relay, also operated by the key, short circuits an adjustable choke in series with the primary of the filament transformer in order to maintain the filament current constant while transmission is taking place.

The diagram in Fig. 15 illustrates the principle of working of the telephonic control circuit. Unnecessary complication has been avoided in this diagram by omitting most of those parts of the circuit which remain the same for telegraphy and telephony, and showing only one modulator valve instead of three in parallel.

The three modulating valves and single control valve can be seen in

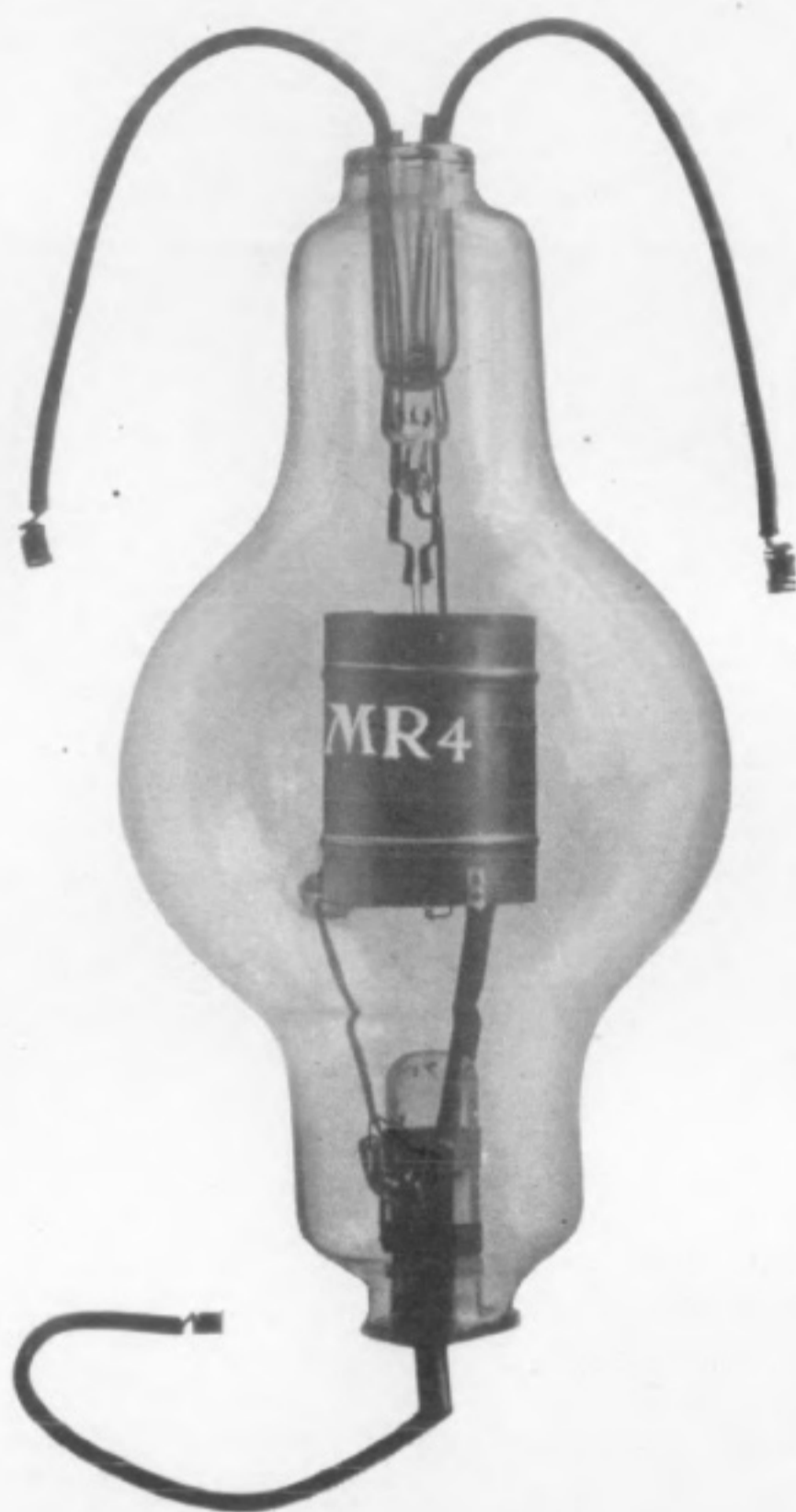

FIG. 17. —M.R. 4 RECTIFYING VALVE.

(To face p. 694)

Fig. 13 mounted on the extreme right hand section of the panel. It will be seen from Fig. 15 that the modulating valves form a resistance in parallel with the aerial, thus absorbing a portion of the energy which would otherwise be radiated. The voice, actuating the microphone, indirectly causes this resistance to vary through the medium of the control valve, which amplifies the variations caused by the microphone. The anode current in this valve is obtained from the same source and rectified by the same valves as the anode current in the power valves. The microphone is incorporated in the remote control unit.

In addition to keying for telegraphy and speaking for telephony, the following operations are also performed by means of the remote control :—

- (a) *Telegraphy-Telephony Change Over.*—When the switch provided for this purpose is put over from telegraphy to telephony, relays are actuated which close the filament lighting circuit of the four speech valves, switch on the high tension supply to the control valve, and short circuit the transmitting key. At the same time an extra choke is inserted, in the smoothing condenser circuits, in order to produce a greater steadying effect on the rectified alternating current. These operations are reversed when the switch is changed back to telegraphy.
- (b) *Send-Receive Change Over.*—The “send-receive” switch actuates relay controlling switches which, at “receive” cut off the power from the key and connect the aerial to the receiver, at the same time disconnecting it from the transmitting circuit.
- (c) *Starting and Stopping Motor.*—This is effected by a third switch, which controls a relay actuating the starting handle of the motor, thus enabling the starting up and shutting down of the set to be effected by the operator.

Critique of Capt. Robinson's Article “A Method of Direction Finding.” *

By Major C. E. PRINCE, O.B.E.

The system of Direction Finding set forth in Captain Robinson's articles in Nos. 5 and 6 of the *RADIO REVIEW*† opens up some interesting points as to its relationship with other and earlier methods, and in many ways invites comments.

Modern direction finding methods are the ultimate outcome of many years of work and progress of many minds, during which time most of the possibilities inherent in present knowledge have been passed under review ; so

* Received September 3rd, 1920.

† *RADIO REVIEW*, 1, pp. 213—219, February, 1920, and pp. 265—275, March, 1920.

that many a so-called novelty is little else than some particular recombination of the well-known elements, or differs only verbally from older practice. The present article is an attempt to analyse the claims made for Captain Robinson's system.

It was in 1905 that Marconi discovered the unsymmetrical radiation of a horizontally bent aerial, but although several ingenious methods (such as that of the 1909 patent of Captain H. J. Round) were devised for direction finding by means of such *directional* aerials, which have no absolute zero direction, these methods were but a stage on the road of progress, and need not detain us here. Nearly all modern work makes use (to keep to the nomenclature which the present writer has sought to standardise)* only of *directive* aerial systems; that is those which give a figure-of-eight polar curve having a complete zero in one plane.

The genesis of the *directive* aerial was contained in a suggestive patent of Mr. S. G. Brown in 1899, the fundamental idea of which is that of using two open vertical aerials half a wavelength apart; but the closed circuit loop or frame aerial is now the sole surviving directive arrangement.

This was introduced into the Bellini-Tosi system by the present writer in 1912, but, apart from its use in such combination, the rotating single frame aerial is now a common device.

Now there are two basic methods of employing a loop or *directive* aerial to determine the direction of an arriving wave which is sweeping over the region occupied by the observer.

The first and most primitive is to rotate the loop in space, and from the observed intensities in varying planes, to find the required direction. Except for secondary considerations (such as convenience, or accuracy), it is immaterial whether observations are made to the maximum or minimum.

This method however, is cumbrous, and an improved method—which is the essence of the Bellini-Tosi system—is to employ two directive aerials fixed in space at right angles, and to connect these each to a small reproduction of itself inside a “radiogoniometer.” The latter will then form a little artificial world, as it were, in which the plane of the field produced by the signal will rotate in sympathy with the field of the larger real world.

The original single plane loop of the primitive system can now be reduced to a small “exploring coil” or loop, rotating in the artificial world.

It is plain that whether the final exploring loop rotates in the real or artificial world is a matter which does not affect its essential *modus operandi*. One cannot therefore, class or criticise either the primitive or the Bellini system by any actions depending upon the polar curve of the exploring loop itself; and it is solely the mathematical nature of the curve that decrees that observations on the maximum are flat and indeterminate, but those on the minimum, where the rate of change is greatest, are sharp and decisive.

The implication then, contained in (a) and (b) on page 214 of Captain Robinson's article is somewhat unjust. Observation about the minimum is not an essential of these two methods, but is indeed employed, on account

* See “The Wireless Direction Finder,” C. E. Prince (*Year Book of Wireless Telegraphy and Telephony*, 1913, pp. 306—317).

of its superior accuracy : and I propose to show that Captain Robinson's system does the like.

Let us now analyse the latter.

His apparatus consists of an aerial system, rotating, as in the primitive method, in the world-field ; but composed of two loops rigidly fixed at right angles one with another. Suppose a direction is just being determined by it, and we consider the position of the coils. One of these, the " main " coil, is in the plane of the arriving signal, and consequently the variation of signal strength by a small movement of a few degrees is negligible.* This may therefore be considered a signal of constant strength, within the limits of searching, and hence this coil takes no part in the determination of direction.

But at right angles to this lies the other rather unhappily named " auxiliary " coil, which really does all the work ! This coil is at right angles to the arriving wave, and is therefore working about its minimum position, where the rate of change is greatest. Any variation of signal strength due to rotation of the system will then be due to the action of this coil alone, which is in fact taking observations on the minimum ; and the whole thing resolves itself into our original primitive loop, but with the addition of a constant signal.

This constant signal may have advantages or conveniences from the operator's point of view, but takes no part, as we have shown, in helping to determine direction.

We see therefore, that this system is in no way free from the disabilities of minimum observations described on page 214. Its accuracy also depends on strength of signal in exactly the same way. If in a plain primitive loop system the loop has to be moved x° from zero in the world-field before a signal becomes audible, so a similar change of angle will be necessary in the Robinson system before any *variation* of signal strength becomes audible.

The only real advantages of the method then, are the secondary and practical ones mentioned in the last paragraph of the introduction. It also carries the disadvantage of ambiguity of two planes touched on by the author on page 265. Though dismissed somewhat lightly, any system suffering from such ambiguity has always been classed (in directional work) as essentially inferior to one not having it. The author seems to imply that there is some real difference between the so-called " main " and " auxiliary " coils ; but assuming for the moment that the two coils are equal, we see that there is no means of deciding which of two planes—that is four directions—the signal is coming from, since either of the coils may act as " main " or " auxiliary " indifferently. A preliminary reading with one of the coils cut out of action is needful to eliminate one of these planes, before the reading proper is taken. This is necessary as long as one of the coils is not sensibly negligible in comparison with the other.

It will be observed though, that Captain Robinson does not make the two loops equal in area-turns, that is, receiving power, and on page 219 an apparently elaborate table is given of sensitiveness for various ratios of

* See curve aa, Fig. 3, of Captain Robinson's article (RADIO REVIEW, p. 217, February, 1920).

“auxiliary” to “main” coil. This table, however, when plotted out, is simply a straight line; and merely amounts to the statement—the larger the auxiliary coil (relative to the other), the better—which is hardly surprising since it is that coil alone which, as we have seen, is actually concerned in the determination; and any effect of the constant-signal or main coil is detrimental to direction-sensitiveness. This can be seen even by inspection of his diagram (Fig. 3), where the slope of the combined curve *cc*, is somewhat less advantageously steep than that of the original “auxiliary” coil curve *bb*.

In spite therefore, of the imposing effect of mathematical and tabular expressions, we come back to the conclusion that this system is nothing more than our old friend the single loop rotated in the world-field, reading about the minimum (with a constant signal added for the convenience of the operator) while the switching over or reversal is equivalent to the mechanical rotation of the loop. This latter point, which is not mentioned by the inventor, seems really the basic point of the system.

Let us now approach the subject from another point of view. If we go back for convenience of thinking to the case in which the auxiliary and main coils are equal, we see at once that the aerial system may be considered as two exploring coils rigidly connected together, so that electrical switching can replace mechanical rotation.

A scheme embodying this idea was devised by Captain H. J. Round about 1913 as a corollary of his patent of 1909. In this a double exploring coil made up of two equal rigidly connected coils, was used, and the receiver was switched rapidly from one to the other. When there was no change of signal strength, the two coils were known to lie symmetrically about the plane of the required direction. Thus both coils were active, and working on a part of the curve where the rate of change is large: it is essentially immaterial whether they are made to work about the minimum or maximum axis, or whether they are set at right angles, or another angle.

The fact that the double exploring coil worked in the radiogoniometer rather than the world-field, was also, by what has been said already, a mere matter of choice; and it is difficult to see in what respect Captain Robinson's system differs essentially from the earlier one, or is any improvement on it.

The setting of one of these coils in the maximum and the other in the minimum position of the field, is merely an extreme case in the adjustment or employment of it, which seems to forfeit one of the best features of Captain Round's scheme of working both coils on a rapidly-changing portion of the curve; and which tends, as we have shown, to revert to the primitive loop. In both methods the exploring system was, after a reading, left at rest, indicating the required direction.

Again if we do allow some credit or essential difference to lie in the disparity of the loops and their particular method of employment, it then verges on a method suggested by the present writer* in which one *directive* and one *non-directional* aerial are employed, except that in this patent the loop or *directive* aerial being very large, and principally intended for ship installations, was not rotatable. Consequently the direction had to be determined

* *British Patent 2457/1912.*

by the strength of signal on the loop relative to what it would have been if in the plane of the loop. For this comparison the circular polar curve of the non-directional aerial served as a standard, and it is fair to say that Captain Robinson's particular use of two such aeri-als was not claimed.

So, we see that, in general, as respects the direction determination only, the real essence of his method is the substitution of switching for rotation, and that by the ingenious method of connection, difficulties of phasing are avoided.

Both this and the Bellini system may therefore be considered as two different methods of avoiding the necessity of mechanically rotating a large and comparatively heavy loop at a speed suitable for practical searching. But, whereas the former method only eliminates the factor of speed—for the loop still has to be rotatable—the latter reduces the only moving parts to extremely small dimensions. Something must move, and in the Bellini exploring coil we have this unavoidable residuum reduced to instrument size, and the world-field (as it were) brought to a focus upon it by the motionless external system. There is no limit to the dimensions of this system. On page 271, section (2), the author hints that the proportionality of E.M.F. to ampere turns may not be indefinitely true, and without plunging too deeply into a matter still awaiting experimental evidence, it seems likely that this is so, and that the few or single turn loop, having a much greater phase-difference between its extreme dimensions, is an arrangement superior to the small multiple coil.

For all these reasons the Bellini system seems to be the most complete basic solution of the directional problem ever proposed.

There remains now to be discussed only the one other factor of Captain Robinson's system—the superimposed constant signal.

By what has already been shown, this signal takes no part in the direction-determination. It is not a technical, but a human or psychological factor. It is often convenient that the operator should be able to hear and read the signal during the whole period of searching; though, in peace time, when no tactical reasons exist for cutting this down to the limit of brevity, it does not seem a very great matter. Even on a radiogoniometer the signal is not really lost while the reading is being made.

More important is the claim that the human ear can more easily judge the relative strength of signals which succeed each other rapidly without passing through silence. This depends entirely upon the personality of the actual operator. The present writer remembers in 1919 interrogating some officers with long experience in direction-finding work on their personal preferences; and the general opinion was in favour of the radiogoniometer method. He cannot but think, however, that there is some basis for this claim.

Even supposing this factor to be of importance, it must not be forgotten that, unless the whole of the present analysis is false, this constant-signal arrangement can be applied to any direction-finding system, and can equally well be quite independent of any of the apparatus or circuits used in the actual determination of direction.

Let us turn now to the application of direction-finding to aircraft—p. 267, section (6).

It will be seen from the author's lucid explanation that there are two methods of applying his system to an aeroplane, which may be briefly described as (1) fixed coils, and the turning of the aeroplane in the world-field; (2) coils movable in the world-field and rotatable with respect to the machine.

(1) This is the only arrangement possible on small machines where there is no room for the larger apparatus. It is satisfactory only for flying direct on to a signal. It is not very practicable for taking bearings, for the machine has to be turned off its course, by an *amount not apparent to the pilot* unless he is also the operator, which change of course is not very welcome to the navigator. This is slow, and has to be done twice to get a cross-bearing; and in each case the compass has to be read immediately after a change of course. For many such reasons its use is limited.

(2) This is only applicable to the larger machines where there is room for movable coils of adequate size, but under these conditions it is a practical system exhibiting all the virtues and defects of the particular method discussed.

But it must not be assumed that aircraft direction-finding stands or falls by either of these methods. It is perfectly practicable to apply the Bellini method to aeroplanes by stringing a pair of single wire loops on the plane, with very successful results; and such an installation will have the virtues which have been discussed in the present paper.

Such an installation was installed by the Marconi Company in the Handley Page machine which was intended for the trans-Atlantic flight. Until this machine was crashed it was navigated with the utmost success by means of it, and it is a record that signals from the English side were picked up at once and determined to within one degree as soon as the machine got into the air at Newfoundland.

In conclusion, although his particular system has been criticised from a technical point of view, the present writer is very much aware of the great services rendered by Captain Robinson to wireless aerial navigation during the war. Making this subject his own, his whole-hearted devotion to it was the means of raising the art (in so far as it related to direction-finding on the machine) to a level of great importance and of instituting a valuable organisation. Only now that peace has given more leisure for the study of the problem, it is necessary to search for the true line of advance, and not to be led aside into unfertile regions.

Under peace conditions the balance of argument is strongly in favour of position finding from ground stations, but for war purposes, or under certain particular circumstances, there is undoubtedly a field for direction-finding from the machine.

A Theory of the Amplitude of Free and Forced Triode Vibrations.

By *BALTH. van der POL, Jun., D.Sc.*

INTRODUCTION.

The conditions to be fulfilled by a circuit linked to a triode in order to generate oscillations have been fully treated by several writers. Their differential equations were mostly confined however to the linear terms and in consequence could be satisfied by any amplitude whatever, though implicitly these differential equations are only valid for infinitesimal oscillations.

As a given triode oscillator, with definite settings of the circuit constants, will generate oscillatory currents with harmonics all having a definite amplitude, it may be worth while to put forward a theory of the oscillating triode having regard to the non-linear terms in the equations. Only in this way can certain properties of a triode system be explained which would otherwise escape the analytical treatment, such as the rectifying action, the interaction of two oscillatory systems, the function of a thermionic bulb as a limiter of amplitude, the working of the heterodyne, the greater magnifications given to small impressed E.M.F.'s than to bigger ones, the generation of higher harmonics, etc.

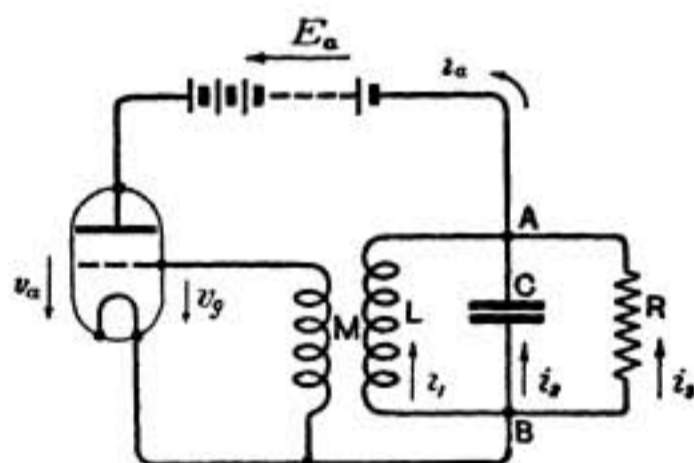

FIG. 1.

When the non-linear terms are retained in the equations the latter, and still more their solutions, soon become very complicated and in order to show clearly and definitely the importance of these terms it seems advisable to treat analytically that system of connections which renders the equations as simple as possible, thus obviating as far as possible, purely analytical complications, and allowing the physical meaning of the formulæ to be clearly seen. This is especially the case in locating the resistance of the oscillatory L C flywheel circuit connected to the anode and filament, not in series either with the self-inductance or capacitance but in parallel to both.

I.—THE TRIODE AS A GENERATOR OF OSCILLATIONS.

1. Let, as indicated in Fig. 1

i_1 be the total current in the self-inductance branch L.

i_2 be the total current in the capacity branch C.

i_3 be the total current in the resistance branch R.

$i_a = i_1 + i_2 + i_3$ be the total anode current.

E_a the E.M.F. of the anode battery.

v_a the plate potential difference
 v_g the grid potential difference } with respect to the filament

then we have

$$L \frac{di_1}{dt} = Ri_3 = \frac{1}{C} \int i_2 dt = E_a - v_a$$

$$M \frac{di_1}{dt} = v_g$$

where M is chosen positive when it has the proper sense to generate oscillations. Eliminating i_1 , i_2 and i_3 we arrive at the simple equation :

$$\frac{di_a}{dt} + \left(\frac{1}{L} + \frac{1}{R} \frac{d}{dt} + C \frac{d^2}{dt^2} \right) (v_a - E_a) = 0 \dots \dots (1)$$

where the grid currents are neglected.

Let further the anode current i_a be a function ϕ of the *single* variable $v_a + gv_g$ (called the "lumped voltage" *) where g is the "voltage ratio" of the tube. Hence

$$i_a = \phi(v_a + gv_g) = \phi \left\{ v_a + g \frac{M}{L} (E_a - v_a) \right\} \dots \dots (2)$$

In the steady, though unstable, state $v_{a_0} = E_a$ as there is no potential drop in the resistanceless branch L. The steady (unstable) anode current we call i_{a_0} ; obviously

$$i_{a_0} = \phi(v_{a_0}) \dots \dots \dots (3)$$

If v be the momentary deviations of the plate potential from the unstable value E_a we have $v_a - v_{a_0} = v$, and the total anode current becomes :

$$i_a = \phi \left\{ v_{a_0} - \left(g \frac{M}{L} - 1 \right) v \right\}$$

or

$$i_a = \phi(v_{a_0} - kv) \dots \dots \dots (4)$$

where

$$k = \left(g \frac{M}{L} - 1 \right)$$

* W. H. Eccles, RADIO REVIEW, 1, p. 73, November, 1919.

If i be the instantaneous deviations of the total plate current i_a from the unstable value i_{a_0} , we have

$$i = i_a - i_{a_0} = \phi(v_{a_0} - kv) - \phi(v_{a_0}) \dots \dots \dots (5)$$

which may be written

$$i = \psi(kv) \dots \dots \dots (6)$$

The fundamental equations of the triode oscillator are therefore

$$\left. \begin{aligned} \frac{di}{dt} + C \frac{d^2v}{dt^2} + \frac{1}{R} \frac{dv}{dt} + \frac{1}{L} v = 0 \\ i = \psi(kv) \end{aligned} \right\} \dots \dots \dots (I. a, b)$$

2. Before proceeding we will first consider the functions ϕ and ψ .

The steady characteristic $i_a = \phi(E_a)$ has the well-known form of Fig. 2. From this characteristic the one of Fig. 3 can readily be derived where i is represented as $i = \psi(kv) = \phi(v_{a_0} - kv) - \phi(v_{a_0})$.

In the latter figure this function has been drawn for the values $k = -1, \frac{1}{2}, 1$ while for $k = 0$, $\psi(kv)$ coincides with the axis of abscissæ.

From this figure, which may be said to represent a family of "derived" characteristics, it is clear that the "falling" characteristic necessary for the generation of oscillations is only obtained when $k > 0$, i.e., for

$$g \frac{M}{L} > 1.$$

In the second part of this paper it will be shown more fully that, if $k = 0$, i.e., $g \frac{M}{L} = 1$, the "resistance" brought into the circuit by the presence of the triode is just compensated for by its regenerative action.

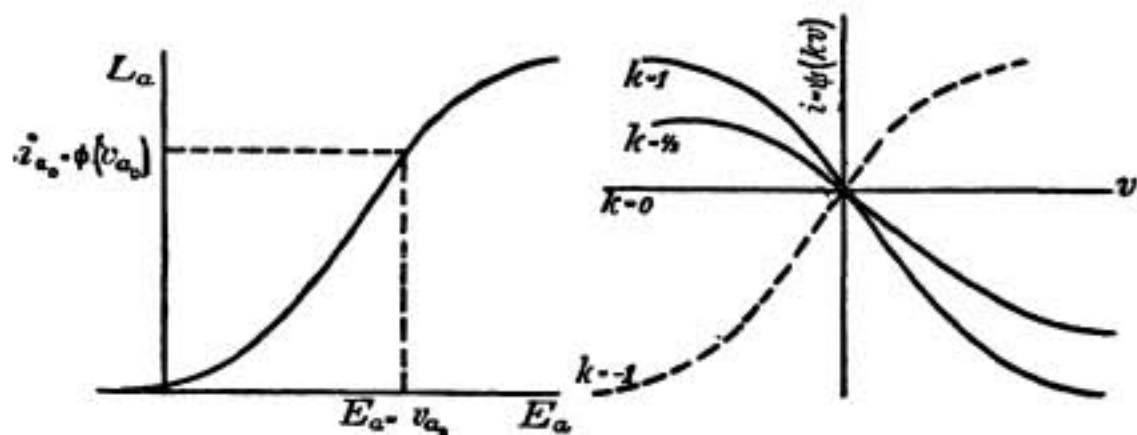

FIG. 2.

FIG. 3.

3. Taking up the analysis again, we see from (2), (4) and (5) that if we assume that the curves in Fig. 3 can be represented by the equation

$$i = \psi(kv) = -\alpha v + \beta v^2 + \gamma v^3 \dots \dots \dots (7)$$

then by Maclaurin's theorem,

$$\left. \begin{aligned} \alpha &= k \left(\frac{\partial i_a}{\partial v_a} \right)_{v_a = E_a} \\ \beta &= \frac{k^2}{2} \left(\frac{\partial^2 i_a}{\partial v_a^2} \right)_{v_a = E_a} \\ \gamma &= -\frac{k^3}{6} \left(\frac{\partial^3 i_a}{\partial v_a^3} \right)_{v_a = E_a} \end{aligned} \right\} \dots \dots \dots (8)$$

where α and γ may be taken positive as long as $k > 0$. If $E_a = v_{a_0}$ is chosen such that i_{a_0} is just half the saturation value while the characteristic is considered symmetrical with regard to the point (v_{a_0}, i_{a_0}) , β will vanish and (I.^{a, b}) will be reduced to

$$C \frac{d^2 v}{dt^2} + \left(\frac{1}{R} - \alpha \right) \frac{dv}{dt} + \frac{1}{L} v + \beta \frac{d(v^2)}{dt} + \gamma \frac{d(v^3)}{dt} = 0 \quad \dots \dots (II.)$$

If our considerations are limited to small oscillations only, both γ and β may be neglected, thus leaving a linear equation with the condition for the generation of an alternating current, that

$$\frac{1}{R} - \alpha = 0.$$

With $\left(\frac{\partial i_a}{\partial v_a} \right)_{v_a = E_a} = h_a = \frac{\alpha}{k},$

$$\left(\frac{\partial i_a}{\partial v_g} \right)_{v_g = 0} = h_g,$$

and

$$g = \frac{h_g}{h_a},$$

this amounts to

$$g \frac{M}{L} - 1 = \frac{1}{R h_a} \quad \dots \dots \dots (9)$$

However, with M greater than the value given by (9) the coefficient of $\frac{dv}{dt}$ in II. becomes negative and the oscillations would build up indefinitely were it not for the presence of the non-linear terms (with γ and β) in II. which put a limit to this increase, or, speaking geometrically: it is the curvature of the characteristic which determines the final amplitude.

4. First Method of finding the Amplitude of the Fundamental.

Our equation II. is closely related to some problems which arise in the analytical treatment of the perturbations of planets by other planets, and of the vibrations of bodies not obeying Hooke's law, upon which Helmholtz's well-known theory of combination tones was based. Hence a somewhat similar way of solving II. may be applied here.*

* In this paragraph we follow closely a method of solution given by Prof. Lorentz in a series of lectures at Leiden University.

Rewriting II. as :

$$\left(\frac{d^2}{dt^2} + \frac{1}{CL} - \epsilon\right) v + \left\{\epsilon + \left(\frac{1}{CR} - \frac{\alpha}{C}\right) \frac{d}{dt}\right\} v + \frac{\beta}{C} \frac{d(v^2)}{dt} + \frac{\gamma}{C} \frac{d(v^3)}{dt} = 0 \quad (10)$$

we introduce a first order correction ϵ to the square of the natural angular frequency ω^2 by putting

$$\omega^2 = \frac{1}{CL} - \epsilon \dots \dots \dots (11)$$

instead of

$$\omega^2 = \frac{1}{CL}$$

Since the voltage is the sum of the fundamental and the various harmonics, we put

$$v = v_1 + v_2 + v_3 + \dots \dots \dots (12)$$

and assume that this series converges, v_1 having the fundamental frequency, v_2 being the first overtone, v_3 the second, etc. Moreover v_1 will be taken to be of the first order of magnitude, v_2 of the second, v_3 of the third, etc.

Putting (12) in (10) we obtain an equation with several terms of different orders of magnitude.

Now equating to zero the sum of all terms of the first order, the sum of all terms of the second order, also of the third order, and limiting ourselves to terms of the third order, it would be impossible to get a solution unless

we also assumed $\left\{\left(\frac{1}{CR} - \frac{\alpha}{C}\right) \frac{d}{dt} + \epsilon\right\}$ to be of the second order. With this

assumption the following equations are obtained :

$$\left(\frac{d^2}{dt^2} + \frac{1}{CL} - \epsilon\right) v_1 = 0 \dots \dots \dots (13)$$

$$\left(\frac{d^2}{dt^2} + \frac{1}{CL} - \epsilon\right) v_2 = -\frac{\beta}{C} \frac{d}{dt} (v_1^2) \dots \dots \dots (14)$$

$$\begin{aligned} \left(\frac{d^2}{dt^2} + \frac{1}{CL} - \epsilon\right) v_3 = & -\left\{\epsilon + \left(\frac{1}{CR} - \frac{\alpha}{C}\right) \frac{d}{dt}\right\} v_1 - \frac{2\beta}{C} \frac{d(v_1 v_2)}{dt} - \\ & - \frac{\gamma}{C} \frac{d(v_1^3)}{dt} \dots \dots \dots (15) \end{aligned}$$

From (13) which is an equation of free oscillations we have

$$v_1 = a \cos \omega t \quad \text{with } \omega^2 = \frac{1}{CL} - \epsilon \dots \dots \dots (16)$$

where a is the unknown amplitude and ω the unknown angular frequency. Equation (14), representing a forced vibration of period 2ω , yields with (16)

$$v_2 = -\frac{a^2 \beta}{3C\omega} \sin 2\omega t \dots \dots \dots (17)$$

Equation (15) represents a forced vibration of periods ω and 3ω . In

order to make sure that v_3 shall only contain terms of the frequency 3ω that part of the impressed E.M.F. in (15) having the frequency ω may now be put equal to zero, thus yielding two equations for the frequency correction ϵ and the fundamental amplitude a .*

We thus find from (15) :

$$\left\{ \epsilon + \left(\frac{1}{CR} - \frac{\alpha}{C} \right) \frac{d}{dt} \right\} a \cos \omega t + \frac{2\beta}{C} \frac{d}{dt} \left(-\frac{a^3\beta}{6C\omega} \sin \omega t \right) + \frac{\gamma}{C} \frac{d}{dt} \left(\frac{3}{4} a^3 \cos \omega t \right) \equiv 0 \dots \dots \dots (18)$$

which must be satisfied at any moment. Hence we obtain for the frequency correction

$$\epsilon = \frac{a^2\beta^2}{3C^2} \dots \dots \dots (19)$$

and for the square of the amplitude of the fundamental

$$a^2 = \frac{4}{3\gamma} \left(\alpha - \frac{1}{R} \right) \dots \dots \dots (20)$$

Finally, after solving also v_3 , the solution of II. is :

$$v = a \cos \omega t - \frac{a^2\beta}{3C\omega} \sin 2\omega t + a^3 \left(\frac{\beta^2}{8\omega^2 C^2} \cos 3\omega t + \frac{3\gamma}{32\omega C} \sin 3\omega t \right) \dots \dots (21)$$

while i contains the steady component $\frac{1}{2}a^2\beta$ which is the shift of the indication of a direct current milliamperemeter in the anode circuit, observed when the system starts generating oscillations.

A steady component does not occur in v which is obvious from the fact that one branch (L) has no resistance.

5. Second Method of finding the Amplitude of the Fundamental.

Instead of finding a solution v which at any moment satisfies (I.^{a,b}) we may from (I.^{a,b}) first derive several energy equations.

Integrating one such equation over the fundamental period gives an equation out of which the time t has disappeared. Next we try to find a quadratic mean value of v satisfying this mean energy equation and thus obtain the value of the amplitude a .

Very suitable for this way of treating the problem is the equation obtained by multiplying (I.^a) by $\int v dt$ and then integrating the result over the unknown fundamental period T .

Integrating by parts yields us the simple energy-equation (the other terms vanishing)

$$\int_0^T i v dt + \frac{1}{R} \int_0^T v^2 dt = 0 \dots \dots \dots (22)$$

* If those terms in the second member of (15) which contain the frequency ω were not identified with zero, so called "secular terms" in v_3 would be necessary (of the form $t \sin \omega t$) which would disturb the purely periodical character of our solution.

We now assume as a first approximation that v varies sinusoidally, hence

$$v = a \cos \omega t$$

$$\therefore \frac{1}{T} \int_0^T v^2 dt = \frac{a^2}{2}$$

Further

$$iv = -\alpha v^2 + \beta v^3 + \gamma v^4$$

yielding

$$\frac{1}{T} \int_0^T iv dt = -\frac{\alpha}{2} a^2 + \frac{3}{8} \gamma a^4.$$

Putting these results in (22) we at once obtain the square of the amplitude :

$$a^2 = \frac{4}{3} \frac{\alpha - \frac{1}{R}}{\gamma}$$

which equals (20) found above.

The assumption (in order to find the amplitude) of v having an accurately sinusoidal form may be justified by the following considerations.



FIG. 4.



FIG. 5.



FIG. 6.

If v is assumed to have the form of Fig. 5 with maximum elongation a' , the mean quadratic value of v is found from (22) to be

$$a'^2 = \frac{5}{3} \frac{\alpha - \frac{1}{R}}{\gamma}$$

while the fundamental harmonic component a is related to a' by the equation

$$a = \frac{8}{\pi^2} a'.$$

Hence for the waveform of Fig. 5 we find

$$a^2 = \frac{64}{\pi^4} \cdot \frac{5}{3} \frac{\alpha - \frac{1}{R}}{\gamma} = 1.095 \frac{\alpha - \frac{1}{R}}{\gamma}$$

or

$$a = 1.047 \frac{\alpha - \frac{1}{R}}{\gamma}.$$

For the widely different waveform of Fig. 6 with maximum elongation a'' , we find in a similar way

$$a^{r2} = \frac{\alpha - \frac{1}{R}}{\gamma}$$

$$a = \frac{4}{\pi} a^r$$

$$\therefore a^2 = \frac{16}{\pi^2} \frac{\alpha - \frac{1}{R}}{\gamma} = 1.620 \frac{\alpha - \frac{1}{R}}{\gamma}$$

or

$$a = 1.274 \frac{\alpha - \frac{1}{R}}{\gamma}$$

Taking the mean of the two a 's from Fig. 5 and Fig. 6 we find a value that differs less than a half of one per cent. from the value of a obtained from the sinusoidal wave form, namely

$$a = 1.155 \frac{\alpha - \frac{1}{R}}{\gamma}$$

Hence we see that the extreme forms of Fig. 5 and Fig. 6 yield amplitudes for the fundamental frequency of v of values only slightly different from the one obtained on the basis of the purely sinusoidal v , and we may accept the result

$$a^2 = \frac{4}{3} \frac{\alpha - \frac{1}{R}}{\gamma} \dots \dots \dots (20)$$

with confidence.

6. Discussion of results so far obtained.—Formula (20) only leads to a stable oscillation with real amplitude when, for $\gamma > 0$, $\alpha > \frac{1}{R}$ i.e., for

$$\left(g \frac{M}{L} - 1\right) > \frac{1}{Rh_a}$$

a^2 would also be positive for both $\gamma < 0$ and $\alpha - \frac{1}{R} < 0$. However the oscillations set up in this case are unstable* so that this case can further be excluded from our physical considerations.

The damping factor of the L C R circuit of Fig. 1 (see also Fig. 7) but disconnected from the triode, is well known to be $\frac{1}{2CR}$. Hence the smaller the shunt resistance the more the natural oscillations of the circuit L C R

* Rayleigh, *Philosophical Magazine*, April, 1883.

will be damped. Similarly the damping factor of a circuit consisting of L , C and r in series, is $\frac{r}{2L}$.

If therefore the latter circuit were connected to the triode, we can, with the accuracy obtained in the above analysis, simply replace $\frac{1}{R}$ by $\frac{Cr}{L}$ and hence obtain for the amplitude of oscillations of such a series resistance circuit

$$a^2 = \frac{4}{3} \frac{\alpha - \frac{Cr}{L}}{\gamma}.$$

The same formula will be found if, *ab initio*, we start formulating the differential equations for the case of a series resistance r . The analysis however is much more complicated.

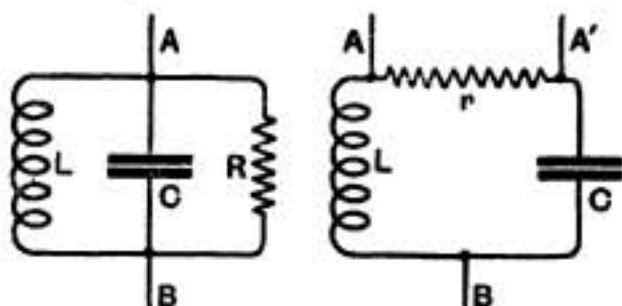

FIG. 7.

As a first approximation it does not matter whether the plate is connected at A or A' (Fig. 7), whether therefore the resistance r is in the L or the C branch. For the sake of simplicity we shall discuss our further results, with the *parallel* resistance R , keeping in mind that the *smaller* is R , the *more* the system is damped.

From (19) and (20) it follows that the frequency correction ϵ , as might be expected, is a function of the amplitude, but also of β , *i.e.*, of $\frac{\partial^2 i_a}{\partial v_a^2}$, whereas the amplitude, as a first approximation, is not affected by the magnitude of β , but only depends upon α and γ , *i.e.*, upon $\frac{\partial i_a}{\partial v_a}$ and $\frac{\partial^3 i_a}{\partial v_a^3}$.

This dependence of the frequency upon the part of the characteristic where the triode is functioning may be illustrated by the following experiment.

It is well known that only with the utmost care can such a small correction experimentally be made evident by altering *e.g.* the grid potential by means of a potentiometer arrangement, as the slightest alteration of the circuits materially affects the tuning conditions. Hence it appears a better course to let the triode itself bring its oscillations on a different part of its characteristic. To this end it is only necessary, instead of connecting the grid directly to the grid coupling coil of M, to insert at this place a large condenser of say $1 \mu\text{F}$.

If the insulating quality of this condenser is not extreme, oscillations will be set up which gradually die down owing to the negative charge accumulating on the grid, the latter thus acquiring a gradually increasing negative potential. After some time (occasionally twenty seconds) the system will suddenly again burst into oscillations and the same phenomena will occur over and over again. If in another (autodyne) system one listens to this phenomena, the audible combination tone is very distinctly heard to alter its pitch during the time the first system oscillates, thus proving clearly the gradual fall of frequency when a triode system vibrates lower down on its characteristic.

The Capacity of Rectangular Plates and a Suggested Formula for the Capacity of Aerials.

By THE EDITOR.

The capacity of any conducting body, whatever its shape, can be determined by the method devised by the author for the calculation of the capacity of multiple wire antennæ. A uniform distribution of charge over the surface is assumed and the average potential calculated; the uniform potential actually obtained when the same total charge is allowed to have its natural distribution will approximate very closely to this average potential. Formulæ can be established for the value of the average potential over surfaces of

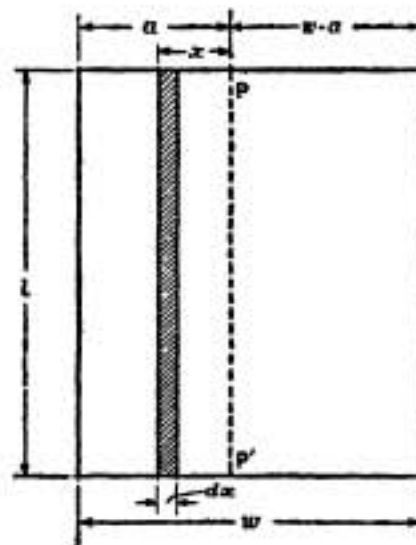

FIG. 1.

simple geometrical form which greatly simplify the calculation. The author has also shown that the same method and formulæ can be used to calculate the resistance to earth of any system of buried conductors. In working out the original formulæ it was assumed that the conductors consisted of round wires, which is of course usually the case with aerials, but in the case of buried conductors copper strip is often employed and the formulæ for round wire cannot be applied. It is, moreover, often necessary to determine approximately the capacity of rectangular plates.

Let a rectangular plate l cms. long and w cms. wide (Fig. 1) have a uniform charge of 1 unit per sq. cm., then the average potential along the line PP' due to the charge on the strip $l \cdot dx$ at a distance x from PP' is given by the formula*

$$\delta V_P = 2 \left(\sinh^{-1} \frac{l}{x} + \frac{x}{l} - \sqrt{1 + \frac{x^2}{l^2}} \right) dx.$$

The average potential along the line PP' due to the whole plate will be

$$V_P = \int_0^a + \int_0^{w-a} 2 \left(\sinh^{-1} \frac{l}{x} + \frac{x}{l} - \sqrt{1 + \frac{x^2}{l^2}} \right) dx$$

now

$$\int \sinh^{-1} \frac{l}{x} dx = x \sinh^{-1} \frac{l}{x} + l \sinh^{-1} \frac{x}{l}$$

$$\int \frac{x dx}{l} = \frac{x^2}{2l}$$

and

$$\int \sqrt{1 + \frac{x^2}{l^2}} dx = \frac{x}{2l} \sqrt{l^2 + x^2} + \frac{l}{2} \sinh^{-1} \frac{x}{l}.$$

Hence the average potential along PP' will be

$$V_P = 2 \left[x \sinh^{-1} \frac{l}{x} + \frac{l}{2} \sinh^{-1} \frac{x}{l} + \frac{x^2}{2l} - \frac{x}{2l} \sqrt{l^2 + x^2} \right]_0^a + \dots \left[\right]_0^{w-a}$$

$$= 2 \left(a \sinh^{-1} \frac{l}{a} + \frac{l}{2} \sinh^{-1} \frac{a}{l} + \frac{a^2}{2l} - \frac{a}{2l} \sqrt{l^2 + a^2} \right)$$

+ a similar expression with $w-a$ instead of a .

The average potential over the whole plate will be

$$\begin{aligned} V &= \frac{1}{w} \int_0^w V_P da \\ &= \frac{2}{w} \int_0^w \left(2a \sinh^{-1} \frac{l}{a} + l \sinh^{-1} \frac{a}{l} + \frac{a^2}{l} - \frac{a}{l} \sqrt{l^2 + a^2} \right) da \\ &= \frac{2}{w} \left[\left(a^2 \sinh^{-1} \frac{l}{a} + l \sqrt{a^2 + l^2} \right) + l \left(a \sinh^{-1} \frac{a}{l} - \sqrt{a^2 + l^2} \right) + \right. \\ &\qquad \qquad \qquad \left. + \frac{a^3}{3l} - \frac{(a^2 + l^2)^{3/2}}{3l} \right]_0^w \end{aligned}$$

* See *Electrician*, 73, p. 859, September, 1914.

$$= 2w \sinh^{-1} \frac{l}{w} + 2l \sinh^{-1} \frac{w}{l} + \frac{2}{3} \frac{w^3 + l^3 - (w^2 + l^2)^{\frac{3}{2}}}{wl}$$

Area of the plate = wl and therefore the charge $Q = wl$ units.

Let

$$\alpha = \frac{l}{w} \quad \text{then } Q = wl = \frac{l^2}{\alpha}$$

For the capacity we have

$$C = \frac{Q}{V} = \frac{l^2}{\alpha V} \text{ cms.}$$

Putting $w = l/\alpha$ in the above formula for V we have

$$C = \frac{l^2}{2\alpha \left\{ \frac{l}{\alpha} \sinh^{-1} \alpha + l \sinh^{-1} \frac{1}{\alpha} + \frac{\alpha^3 + 1 - (\alpha^2 + 1)^{\frac{3}{2}}}{3\alpha^2} l \right\}} \text{ cms.}$$

$$= \frac{\sqrt{wl}}{2\sqrt{\alpha} \left\{ \frac{\sinh^{-1} \alpha}{\alpha} + \sinh^{-1} \frac{1}{\alpha} + \frac{\alpha}{3} + \frac{1}{3\alpha^2} - \frac{(\alpha^2 + 1)^{\frac{3}{2}}}{3\alpha^2} \right\}} \text{ cms.}$$

$$= k \sqrt{wl} \text{ centimetres}$$

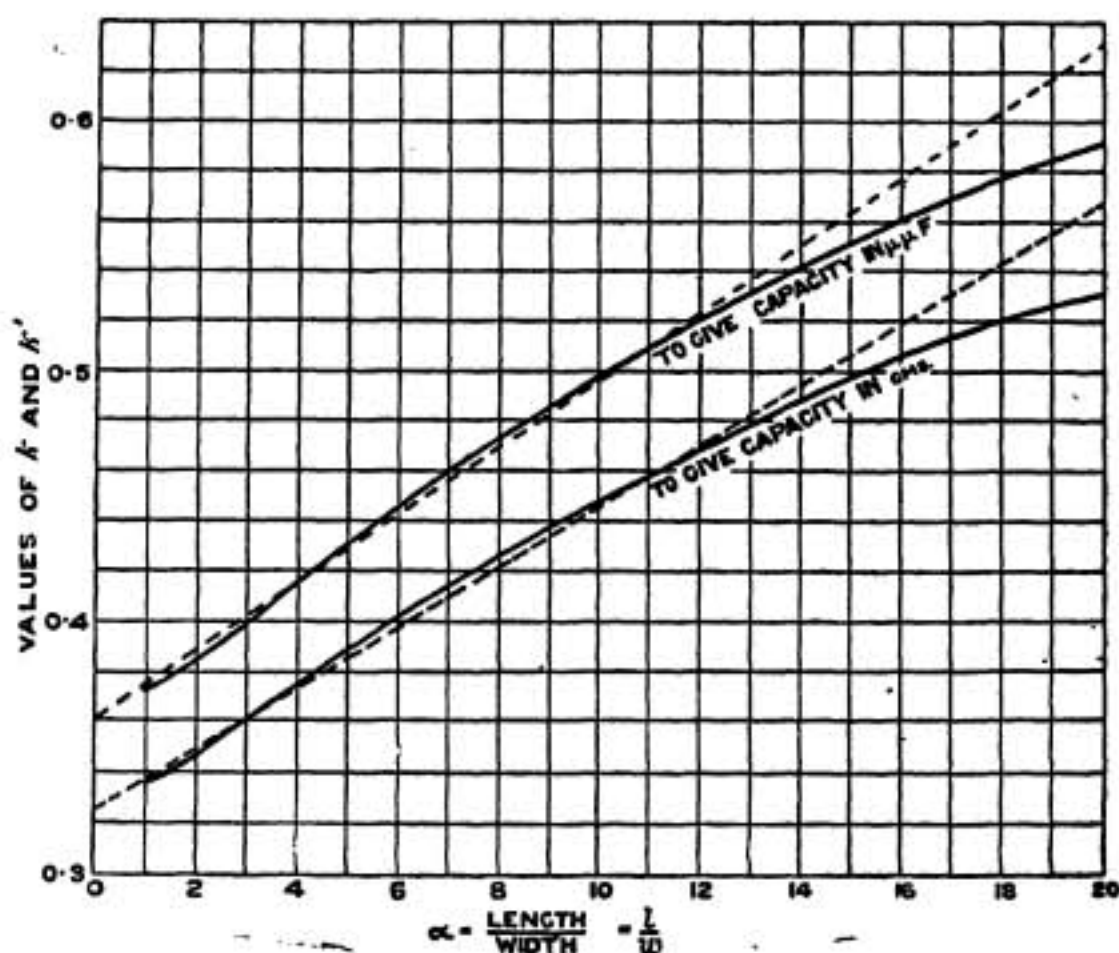

FIG. 2.

where k is a coefficient depending only on α . The values of k for a number of values of α are given in Table I. For intermediate values they can be read off the lower curve in Fig. 2. To obtain the capacity in micro-microfarads the above values must be divided by 0.9 (upper curve in Fig. 2).

TABLE I.

$\alpha =$	1	2	3	4	5	10	20
$k =$	0.336	0.346	0.360	0.374	0.388	0.448	0.532
$\frac{k}{0.9} =$	0.373	0.384	0.400	0.415	0.431	0.498	0.591

From the dotted straight lines in Fig. 2 it is seen that the value of k is given approximately by the equation

$$k = 0.324(1 + 0.0375\alpha).$$

This is applicable for ratios of length to width up to 12 or 14.

It is of interest to compare this with an empirical result obtained by Austin from the measured capacity of multiple wire rectangular aerials,* viz.

$$C = \left(4\sqrt{a} + 0.885\frac{a}{h}\right)\left(1 + 0.015\frac{l}{w}\right) \times 10^{-5} \text{ microfarads}$$

where a is the area in square metres and h is the height in metres.

Adopting these units and nomenclature our calculated formula becomes

$$C = 3.6\sqrt{a} \cdot \left(1 + 0.0375\frac{l}{w}\right) \times 10^{-5} \text{ microfarads.}$$

Austin's formula is only applicable if the aerial wires are closely spaced, and in this case, as we have already shown,† the capacity approximates closely to that of a whole surface.

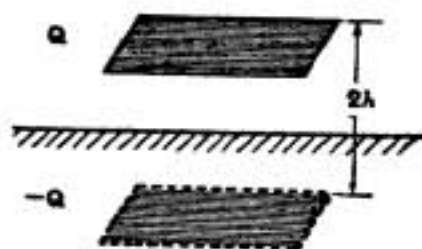

FIG. 3.

The other term in Austin's formula is due to the proximity of the earth. This may be calculated by finding the effect on the potential of the aerial of its image in the earth. If the area of the plate or aerial is small compared with the height, little error is made in assuming that the potential of the

* *Proceedings Institute of Radio Engineers*, 8, p. 164, April, 1920.

† *Electrician*, 73, p. 861, Fig. 15, September, 1914.

aerial due to the charge on its image is $-\frac{Q}{2h}$. It will in fact be slightly less because $2h$ is the minimum distance between the two charges (Fig. 3).

Ignoring the effect of the earth, we have seen that the calculated capacity may be written

$$C = k \sqrt{wl} \text{ cms.}$$

and therefore

$$V = \frac{Q}{C} = \frac{wl}{k \sqrt{wl}} = \frac{\sqrt{wl}}{k}.$$

The presence of the earth reduces the potential to

$$\frac{\sqrt{wl}}{k} - \frac{wl}{2h} = \frac{\sqrt{wl}}{k} \left(1 - \frac{k \sqrt{wl}}{2h}\right).$$

The quantity in brackets is the ratio in which the potential is reduced and therefore its reciprocal is the ratio in which the capacity is increased. If $\frac{k \sqrt{wl}}{2h}$ is small compared with unity, this reciprocal is approximately

$$1 + \frac{k \sqrt{wl}}{2h}.$$

The total capacity is therefore

$$C = k \sqrt{wl} \left(1 + \frac{k \sqrt{wl}}{2h}\right) \text{ cms.}$$

Putting in the approximate linear equation for k , viz.,

$$k = 0.324 (1 + 0.0375\alpha),$$

we have

$$\begin{aligned} C &= (1 + 0.0375\alpha) \left(0.324 \sqrt{wl} + \frac{0.105 (1 + 0.0375\alpha) wl}{2h}\right) \text{ cms.} \\ &= (1 + 0.0375\alpha) \left(0.324 \sqrt{wl} + 0.0525 \frac{wl}{h} (1 + 0.0375\alpha)\right) \text{ cms.} \end{aligned}$$

All the dimensions and the capacity are in cms. With Dr. Austin's units and nomenclature our formula becomes

$$C = \left\{ 3.6 \sqrt{a} + 0.58 \frac{a}{h} \left(1 + 0.0375 \frac{l}{w}\right) \right\} \left(1 + 0.0375 \frac{l}{w}\right) \times 10^{-5} \text{ microfds.}$$

This involves a slight difference from the form of Dr. Austin's equation, but the effect of the additional factor may be too small to be detected by measurements on aerials. In view of the difficulty of making due allowance for various disturbing factors, such as down leads, masts, stays, etc., such measurements cannot be made with a high degree of accuracy. The following examples illustrate, however, the close agreement between the theoretical and the experimental formulæ. If $l/w = 5$, Austin's formula is $4.3\sqrt{a} + 0.95 a/h$, whilst ours is $4.27\sqrt{a} + 0.816 a/h$; if $l/w = 10$, Austin's formula is $4.6\sqrt{a} + 1.02 a/h$, and ours $4.95\sqrt{a} + 1.095 a/h$.

Multiplex Telephony and Telegraphy using High Frequency Currents (Wired Wireless).*

By K. W. WAGNER.

A year ago the author read a paper † on the same subject in which he considered its historical, theoretical and technical aspects, and referred to successful experiments that had been made. In the present paper he gives an account of practical tests under working conditions carried out by the German Telegraph Department during the past year.

I. MULTIPLEX TELEPHONY.

In the beginning of 1919 three simultaneous conversations were carried out on a 3 mm. bronze line between Berlin and Hanover (300 km.). This was done under practical working conditions, that is to say, any subscriber in Berlin was connected through from the local to the main exchange and then made use of the high-frequency service to Hanover where the connection to the desired subscriber was completed. Although successful several months' work was required to overcome the gap between experimental success with the apparatus under the watchful care of physicists and engineers and the installation of apparatus which would stand the ordinary conditions of service in the hands of less trained *personnel*. It was essential that the apparatus should be simple to operate and, in view of the present cost of labour, that it should be as automatic as possible. At the same time the cost of upkeep and of renewals must be kept as low as possible.

In addition to these general requirements, it was essential in the present case that the high-frequency connection should be made and controlled by the operator in exactly the same way as the ordinary line connection. For example, it must be made impossible for two operators to attempt to use any high-frequency connection at the same time.

It was also essential that in case of breakdown or trouble of any kind the attendants in the high-frequency rooms at Berlin and Hanover could communicate without the provision of a new line and that the necessary switching to make this connection should be as simple and rapid as possible.

At the beginning of October, 1919, the triple connection on the Berlin-Hanover wire was ready for service. From that time it has been in daily use for eight to ten hours with complete satisfaction. Each of the three sets handle up to 120 conversations of three minutes duration per day. The articulation leaves nothing to be desired; the loudness has been adjusted to equality with the ordinary connection, corresponding to $\beta l = 1.3$, that is, it reaches a high standard. When, on account of noises due to imperfect earthing, ordinary telephony had to be interrupted, the high-frequency communication could still be carried on.

The high-frequency apparatus is in a special room, the separation being necessary to the organisation and operation of the exchange. The high-

* From a paper read before the Elektrotechnische Verein, Berlin, on May 18th, 1920.

† *Elektrotechnische Zeitschrift*, 40, p. 383, August 7th, and p. 394, August 14th, 1919.

frequency room requires only a single official with a female assistant; even on changing over to another wire no fresh adjustment is required. The present *personnel* could control considerably more apparatus.

The system has also been tried under working conditions between Berlin and Frankfurt, a distance of 600 km.

The oscillation generator contains two 10-watt tubes and its frequency can be adjusted between 15,000 and 1,500,000. The receivers and three-stage amplifiers are of the ordinary type.

Although there is no fundamental difficulty in carrying ten or more conversations on one wire it was decided to perfect and thoroughly test the more modest attainment of three conversations on a single wire. From the results obtained there is no doubt that in high-frequency multiplex telephony a way has been found of considerably improving the position with respect to the need for further telephonic facilities.

II. MULTIPLEX TELEGRAPHY.

In many respects high-frequency telegraphy is simpler than the analogous telephonic problem, and although the decision to pass from the successful laboratory experiments to the practical application was taken later in the case of telegraphy, this was only because the need was not so great. In both cases the need was greatest on the main lines of communication and it was for that reason that tests were made on one of the principal routes, viz. Berlin-Frankfurt. The traffic is very heavy and is carried by double-current Siemens high-speed printers. In the high-frequency system the Siemens transmitter sends its positive and negative currents, not to the line, but to a relay, which connects and disconnects the high-frequency transmitter and the line. At the receiving end, the currents are amplified before passing to a thermionic relay (two double-grid tubes) which operates the double-current receiver. The high-frequency currents can be amplified, or a heterodyne can be employed and the beats amplified; both methods have been successfully employed. Such a system with two simultaneous messages has been working over the 600-km. line since January for eight to nine hours per day and handling up to 2,000 telegrams daily; this is about 30 per cent. of the total traffic between Berlin and Frankfurt. The high-frequency apparatus is in a separate room and in Berlin the high-frequency currents pass through 1 km. of ordinary telephone cable (0.8 mm.) to the telephone exchange where it passes to the telephone line. The line is used at the same time for telephony without any interference. The duplex working has since been replaced by six-fold telegraphy over a single line which is used at the same time for telephony. This is capable of handling 16,000 telegrams per day.

Satisfactory tests have also been made between Berlin and Magdeburg (150 km.) in the operation of Hughes apparatus over the telephone line, in a similar manner to that described above.

The author concludes by saying that the successful results obtained lead one to hope that high-frequency operation will help them in the difficult task of raising the telephonic and telegraphic facilities to their old standard.

Review of Radio Literature.

1. Articles and Patents.

1042. THE THEORY OF THE BARETTER. K. Kūpfmüller. (*Telegraphen- und Fernsprech-Technik*, 9, pp. 60—63, July, 1920.)

A mathematical proof that if the alternating current contain harmonics, a reversal of connections to the baretter wire will give a different reading. This is due to the temperature and resistance of the wire following the alternations of the current to some extent; the effect will therefore be less the higher the frequency. A case is quoted in which a difference of 1 per cent. was observed at a frequency of 800.

1043. PERIOD AND DECREMENT OF AN OSCILLATORY CIRCUIT WITH A SHORT-CIRCUITED SECONDARY. I. Jones. (*Philosophical Magazine*, 39, pp. 553—565, May 1920. *Science Abstracts*, 23A, p. 400, Abstract No. 1007, July 31st, 1920—Abstract.)

This article gives a mathematical treatment of the oscillations in a primary circuit to which a short-circuited secondary is coupled. It is assumed that the secondary capacity is negligible and that its resistance may be varied. Calculation shows that the general effect upon damping of the oscillations caused by increasing R_2/L_2 with constant coupling, is an almost linear increase and that the frequency diminishes as R_2/L_2 increases, the diminution being more rapid the greater the value of the coupling. The decrement increases with the coupling and corresponding curves are given for the effects on the frequency. It is also shown that there is a limiting value of k^2 below which oscillations are set up for all values of R_2/L_2 and above which there is a range in which no oscillations are produced. This limiting value is 0.889. (k = Coupling coefficient. R_2 = Secondary resistance. L_2 = Secondary inductance.)

1044. RECENT EXPERIMENTAL WORK IN RADIOTELEGRAPHY. F. Kiebitz. (*Telegraphen- und Fernsprech-Technik*, 9, pp. 88—90, August, 1920.)

This is an interim report of the Telegraph Department. The following subjects are dealt with: The directive effect of bent aeriels; in some cases no directive effect is found. A comparison of elevated and earth antenna. The action of the dry soil above the water level near the aerial. An attempt to show experimental and directive effect by means of the auxiliary aerial suggested by Abraham was not successful. Little if any connection could be traced between the atmospheric disturbances and the meteorological conditions. The permissible strength of a disturbing signal was investigated for different conditions as regards wavelengths and tones of the two sending stations. The variation of frequency of various C.W. stations was observed. Comparative tests are being made on high and low frequency amplifiers and also of separate and self-heterodyne systems. Wireless telephony tests are being carried on between Alt-Strelitz and Lärz to test various methods of modulation. A method has been devised for the measurement of very weak coupling. Experiments are being made for operating a Wheatstone high-speed receiver through a series of amplifiers and rectifiers.

1045. THE SIGNIFICANCE OF MAXWELL'S THEORY. A. Press. (*Electrician*, 85, pp. 177—178, August 13th, 1920.)

The author considers the longitudinal formation of a line of force at an infinite speed, in distinction of its lateral propagation at the speed of light, and criticises the interpretation usually placed upon the Maxwellian equations of wave propagation. In view of the circuital nature of all currents in the Maxwellian equations, it is maintained that the present theories of the space charge in triode valves require careful revision. It is stated that the author intends to return to the subject of wave propagation in a subsequent communication.

1046. NOTE ON RADIO FREQUENCY MEASUREMENTS. C. Englund. (*Proceedings of the Institute of Radio Engineers*, 8, pp. 326—333, August, 1920.)

Deals critically with the need for and design of a radio-frequency bridge suitable for general use. The methods developed for use at the Western Electric Co.'s Engineering Laboratory are briefly described. With frequencies up to 200,000 radio-frequency bridge measurements are not very troublesome but with 1,000,000 cycles the spacing and shielding of generator, bridge and detector are all-important. Shielding against electromagnetic induction has not proved successful in eliminating interference but electrostatic shields have been found quite successful.

The generator of the bridge scheme here advocated consists of a valve set, the negative end of the filament being earthed and the generator inductance unit being a toroidal coil. If no terminal of the bridge proper may be grounded two transformers for input and output are necessary while each section of the bridge is electrostatically shielded. The balance is observed by ear up to 10,000 cycles, but above this frequency the beat method with separate heterodyne oscillator is used and it is possible to balance much more accurately than is justified by the standards available. Air condensers with negligible dielectric losses (calibrated at low frequency) and resistances have been used as the basis of the work. Coils are tuned with such a condenser and measured as pure resistances. The so-called "shunt" capacity of a coil is determined by successively balancing the coil with the standard condenser at two frequencies. The "shunt" capacity C_0 may then be determined from the formula

$$C_0 = \frac{C_1 - \frac{\omega_2^2}{\omega_1^2} C_2}{\frac{\omega_2^2}{\omega_1^2} - 1}$$

where C_1 and C_2 are the balancing capacities at frequencies ω_1 and ω_2 respectively.

Absolute frequency determinations are made by bridging the gap from an audio frequency (tuning fork or siren) and the desired radio frequency by means of a valve oscillator with multiple harmonics. (See also RADIO REVIEW Abstract No. 1, October, 1919.)

1047. THE MEASUREMENT OF VERY SHORT TIME INTERVALS. P. E. Klopsteg. (*Physical Review*, 15, pp. 12—23, January, 1920. *Science Abstracts*, 23A, pp. 313—314, Abstract No. 792, June 30th, 1920—Abstract.)

For the determination of time intervals of the order of microseconds the method employed involves the determination of the potential difference of a condenser after it has been discharged for the interval of time to be measured. The particular novelty of the method described by the author lies in the use of a ballistic galvanometer in conjunction with a known potential difference or a potentiometer to determine the voltage of the condenser after discharge. The galvanometer deflection is due to the difference between the potential of the condenser and the comparison voltage and can therefore be made very small giving considerable accuracy.

1048. THE USE OF CONDENSERS IN HIGH-VOLTAGE MEASUREMENTS. A. Imhof. (*Bulletin of the Schweizerische Elektrotechnische Verein*, 11, pp. 99—104, May, 1920. *Science Abstracts*, 23B, pp. 335—336, Abstract No. 659, July 31st, 1920. *Technical Review*, 6, p. 724, August 31st, 1920—Abstract.)

This paper investigates various arrangements of condensers for subdividing a high voltage for measurement purposes, and points out the errors that may arise and how they may be overcome.

1049. SPARK GAP. F. Lowenstein. (*French Patent* 500709, June 14th, 1919. Published March 23rd, 1920.)

The principal object is to provide a quenched spark gap of relatively simple construction,

in which the component parts shall be individually movable and replaceable without disassembling the apparatus as a whole, and to provide easy means of adjustment. In one form the apparatus comprises a supporting plate of insulating material, a casing closed at one end by said plate, a plurality of tubular spark gap elements mounted in line with suitable apertures in said plate and electrically connected in series, a fan being arranged to move air through the casing to cool the gap elements. Each spark gap element comprises inner and outer conducting shells arranged co-axially, insulating rings spacing the shells apart to provide the spark gap, and ribs extending into the wider portions of the gap. A switch is provided to allow any number of spark gap elements to be connected in circuit.*

1050. APPARATUS FOR GENERATING OSCILLATIONS. C. Lorenz. (*German Patent* 306495, August 22nd, 1917. Patent granted October 10th, 1919. Addition to *German Patent* 300777. *Jahrbuch Zeitschrift für drahtlose Telegraphie*, 15, p. 503, June, 1920.)

An antenna excited by impulses from an electromagnetic buzzer circuit. See Fig. 1.

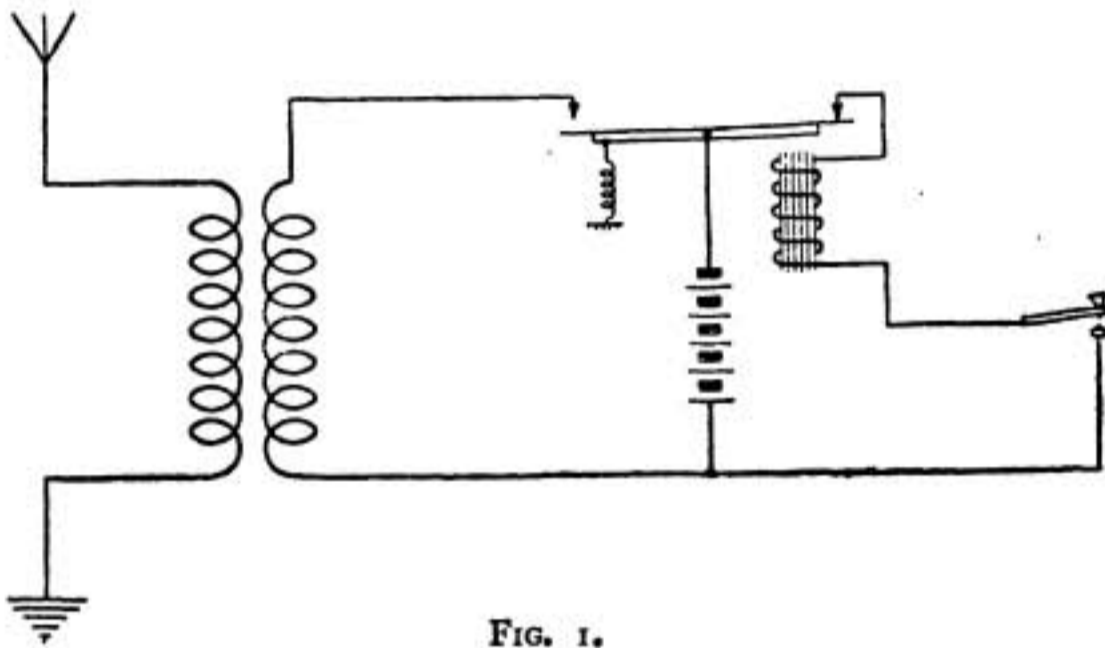

FIG. 1.

1051. APPARATUS FOR GENERATING OSCILLATIONS. E. F. Huth and B. Rosenbaum. (*German Patent* 307191, June 1st, 1915. Patent granted October 6th, 1919. *Jahrbuch Zeitschrift für drahtlose Telegraphie*, 15, p. 492, June, 1920—Abstract.)

An arrangement for generating damped oscillations by an automatic electromagnetic contact breaker in which the self-induced "extra" E.M.F. of the electromagnet coil is used as charging voltage.

1052. APPARATUS FOR GENERATION OF OSCILLATIONS. Studien-Gesellschaft für Electriche Leuchtröhren. (*German Patent* 306317, November 3rd, 1917. Patent granted October 28th, 1919. *Jahrbuch Zeitschrift für drahtlose Telegraphie*, 15, p. 166, February, 1920—Abstract.)

A circuit in which the gap of a spark set transmitter is replaced by a discharge tube filled with one of the inert gases and provided with two electrodes of easily vaporisable metal.

1053. CONTINUOUS WAVE GENERATOR. Société Française Radio-Électrique. (*French Patent* 502160, March 20th, 1915. Published May 6th, 1920.)

The invention relates to the use of a mercury arc for the generation of electrical oscillations.

* See also RADIO REVIEW Abstract No. 110, January, 1920.

The arc is formed in a vacuum tube T (Fig. 2) between an anode A formed, for example, of graphite, and a cathode K of mercury. The arc is fed by a continuous current from X, while R is a resistance in series therewith. A particular point in the construction of the apparatus is a platinum point p fixed in the cathode and also an auxiliary arc with an anode B fed from a

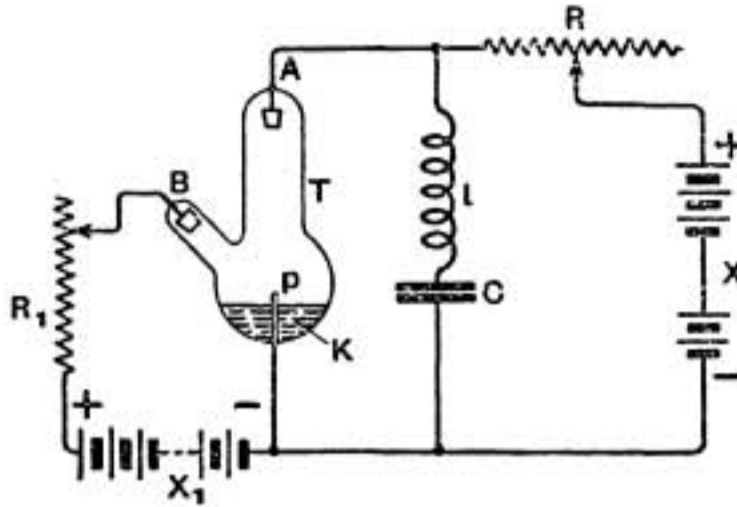

FIG. 2.

source X_1 , through resistance R_1 . The auxiliary arc forms a means of starting the main arc. To obtain the continuous waves an inductance L and a capacity C are connected across the main arc A, K.*

1054. ARC GENERATOR. O. Scheller and C. Lorenz Aktiengesellschaft. (*German Patent 298973*, May 28th, 1915. Patent granted October 9th, 1919. *Jahrbuch Zeitschrift für drahtlose Telegraphie*, 15, pp. 171—172, February, 1920—Abstract.)

An arc generator of sustained waves in which the electrodes are not in the same straight line. The arc burns in a closed chamber and in a magnetic field.

1055. CONTINUOUS WAVE TRANSMITTER. Société Française Radio-Électrique. (*French Patent 502639*, December 8th, 1915. Published May 21st, 1920.)

The specification describes an arrangement of a mercury vapour tube for the production of continuous waves. For further particulars, see British Patent No. 126030.

1056. THE POULSEN ARC PLANT AT KÖNIGSWUSTERHAUSEN. H. Thurn. (*Telegraphen- und Fernsprech-Technik*, 9, pp. 37—42, June, 1920; pp. 55—60, July, 1920. *Elektrotechnische Zeitschrift*, 41, pp. 686—687, September 2nd, 1920—Abstract.)

A description of the aerial (five masts 150 metres high) and of two arcs by Lorenz of Berlin supplying 32 kW and 5 kW respectively to the aerial. Of interest is a note to the effect that both electrodes are now of carbon and both rotate; they are not in line but at 90° forming an inverted V. It is stated that a method of sending is used in which by increasing the damping the aerial current is reduced to zero and the power taken by the arc greatly reduced in the spaces between the Morse signals. Photographs of the arcs and a diagram of connections are given. Various pieces of auxiliary apparatus are also described. The oscillation of the aerial is tested by a vacuum tube rotated at high speed in a darkened case.

A diagram of connections is given of a magnetically operated sending key relay and of a new type of wavemeter. The latter is shown in Fig. 3.

$C_1 L_1 C_2 L_2$ are connected in series, $C_1 = C_2$, but $L_1 = 2.5 L_2$. The instrument covers the range between the frequencies for which $C_2 L_2$ and $C_1 L_1$ respectively are in resonance. Hence

* See also *U.S. Patent 1131190* (1910), by E. Weintraub, for a description of a very similar arrangement.

as the frequency increases the impedance of C_1L_1 increases and that of C_2L_2 decreases, thus varying the ratio of the currents in the two fixed coils at right-angles and with it the position

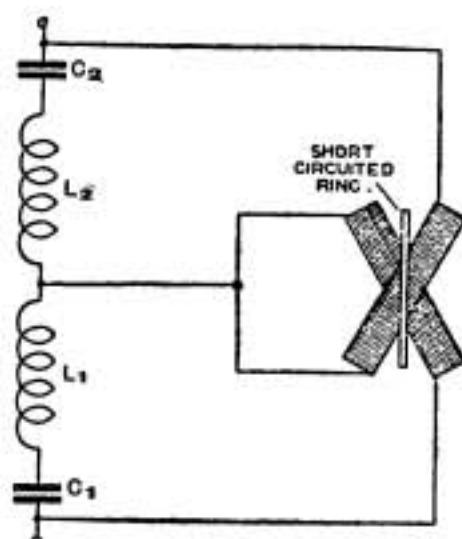

FIG. 3.

of the freely rotating copper ring turning within them. A pointer is attached to the spindle carrying the ring.

The article concludes with references to experiments in telephony, details of which cannot yet be published.

1057. HIGH FREQUENCY ALTERNATOR. Société Française Radio-Électrique. (*French Patent 502604*, September 16th, 1915. Published May 21st, 1920.)

The alternator is of the variable inductance type and the rotor and the stator are laminated in a direction parallel with the shaft, and comprise sets of plates forming teeth which are separated by non-magnetic material or by air gaps. The excitation and armature windings consist of coils concentric with the shaft and a single coil may serve both as excitation and as armature winding. A number of coils may be arranged on the stator with their sides displaced axially, which coils may be connected in parallel or series. For further particulars of this invention see British Patent No. 102738.

1058. TRANSMITTER AND RECEIVER FOR WIRELESS TELEGRAPHY. Gesellschaft für drahtlose Telegraphie. (*German Patent 310162*, April 20th, 1918. Patent granted September 20th, 1919. *Jahrbuch Zeitschrift für drahtlose Telegraphie*, 15, p. 82, January, 1920—Abstract.)

A simple triode generating circuit with back-coupling in which the grid coil possesses inductance alone, so that, together with the internal capacity of the tube an oscillating circuit is formed, the wavelength of which is much smaller than the smallest wavelength of the main circuit.

1059. THE AUDION OSCILLATOR. R. A. Heising. *Journal of the American Institute of Electrical Engineers*, 39, pp. 365—376, April, 1920, and pp. 471—478, May, 1920. *Electrical World*, 75, p. 1101, May 8th, 1920—Abstract. *Technical Review*, 6, pp. 506—507, June 8th, 1920—Abstract.)

The article covers the theory and operation of triode valve oscillator circuits. Vector diagrams are given of the phase relations in various circuits and the behaviour of the oscillator is considered as a function of its many variables, a series of curves being given in terms of the six independent variables of the circuit. The problem of securing high efficiency is also discussed. The scope of the paper may best be indicated by a list of the most important sections:—General oscillator circuits; The simple oscillator circuit; Simple vector diagrams; Vector diagram including resistance; Vector diagram with mutual inductance between grid

and plate circuits; Phase relations in the Colpitts circuit; The ordinary feed-back circuit; Determination of frequency; Application to complex circuits; Coupled circuits; Feed-back circuits; Operation point on the characteristic curves; Dynamic characteristic of an audion with attached circuit; Coupling for power; Audion output impedance; Coupling adjustment; Audion load circuit; Oscillator behaviour as a function of its variables; Variation with filament current, with coupling, with input on grid, with antenna resistance and with grid resistance; Efficiency; Oscillator adjustments, and adjustments for multi-tube oscillators.

1060. THE FIRST WIRELESS TELEPHONE EXCHANGE. (*Telegraph and Telephone Age*, 38, p. 425, August 1st, 1920.)

A note referring to the installation of a special telephone exchange at Avalon, Catalina Island off the Californian coast for providing automatic relay connection between the subscribers' telephone stations at Catalina Island and the mainland.

1061. WIRELESS TELEPHONES. Société Française Radio-Électrique. (*French Patent* 502722, February 15th, 1916. Published May 25th, 1920.)

This specification describes a wireless telephone apparatus using a triode valve. For details, see British Patent 127008.

1062. WIRELESS TELEPHONY. W. H. Eccles. (*Nature*, 105, pp. 519—522, June 24th, 1920.)

The author first points out the recent advances that have been made in wireless telephony and then proceeds to summarise the leading methods of telephonic modulation of a C.W. source. In addition to direct modulation by a microphone in the aerial circuit, Fessenden's condenser microphones, Alexanderson's magnetic modulator and various forms of valve modulation are briefly described. At the end of the article two examples are quoted of high power plants, the first being the Western Electric Company's apparatus which was used for speaking across the Atlantic and from Arlington to Honolulu and the second the 20 kW set recently erected by Marconi's Wireless Telegraph Company. An outline connection scheme for the latter apparatus is included and shows that the modulation is effected by a number of absorption valves shunting the aerial circuit.

1063. DUPLEX WIRELESS TELEPHONY: SOME EXPERIMENTS ON ITS APPLICATION TO AIRCRAFT. P. P. Eckersley. (*Journal of the Institution of Electrical Engineers*, 58, pp. 555—565; Discussion, pp. 565—571, July, 1920. *Model Engineer*, 43, pp. 111—115, August 5th, 1920; also pp. 126—130, August 12th, 1920—Abstract.)

Paper read before the Institution of Electrical Engineers (for abstract see RADIO REVIEW, 1, pp. 338—340, 383—385, April and May, 1920*), together with an appendix communicated after the reading of the paper and the discussion.

The additional appendix deals with the equations expressing the frequencies of the radiated waves with voice modulation superimposed upon the steady C.W. The possibility of eliminating the initial unmodulated C.W. frequency, or the carrier wave frequency, is also discussed, and it is pointed out that with a "quiescent aerial transmitter," of the type described in the paper, this may be effected by arranging matters so that the speech modulation is as much above as below the line of zero amplitude. A suggestion is also made as to the manner in which it might be possible to modify the circuits described in the paper to realise these conditions.

In the discussion some curves are given by C. L. Fortescue to explain the bad speed obtained with the quiescent aerial transmitter as compared with the ordinary modulated transmitter. In the former case unwanted harmonics may be introduced at the receiver by reason of the unsymmetrical waveform. The question of the lag in the establishment of the H.F. oscilla-

* See also RADIO REVIEW Abstract No. 623, August, 1920, for further references.

tions was also dealt with by H. M. Dowsett and P. P. Eckersley, the former showing that the valves themselves could not account for a greater lag than about 10^{-5} sec. and that therefore the observed lags of $1/300$ sec. must be attributed to the circuits themselves. H. J. Round's suggestion that the bad speech is due to the successive wave trains not being in phase in the quiescent aerial transmitters whereas in the cases where a feeble oscillation is permanently maintained they are in phase, appears to be the most promising.

1064. RECEIVING AERIALS AND CIRCUITS. G. Leithauser. (*Jahrbuch Zeitschrift für drahtlose Telegraphie*, 15, pp. 178—200, March, 1920.)

A study of the arrangements for allowing reception to be carried on while transmitting by means of a neighbouring aerial, as in duplex workings.

With a high degree of amplification one cannot use earthed aerials or even ordinary counterpoises because of the disturbing noises, one must employ open or closed directive systems. A horizontal insulated wire 200 metres long and 6 to 10 metres above the ground gives disturbing noises owing to rapid changes of air potential. Several methods of supporting large closed aerials on masts are discussed. The author then describes the heterodyne method of reception and the use of amplifiers. He discusses the relative advantages of large and small frame aerials. In a room where a large rotating coil is inconvenient, coils can be mounted flat on the four walls and connected to a radiogoniometer. He states that atmospheric disturbances are less with high narrow coils than with low wide coils.

1065. EXPERIMENTS AND TESTS WITH WIRELESS HIGH-SPEED TELEGRAPHY. F. Banneitz. (*Telegraphen- und Fernsprech-Technik*, 9, pp. 90—93, August, 1920.)

A description of a high-speed wireless system which has been developed in connection with the network of wireless stations now being established throughout Germany. The transmitter consists of thermionic tubes delivering 800 watts to the aerial which is not directly connected to the tubes but coupled to the oscillatory anode circuit. It is essential to secure the antenna very rigidly to prevent small changes of capacity due to the wind. In the grid circuit is a double-current relay operated by a Wheatstone high-speed transmitter. The receiving aerial is coupled through a number of amplifiers to the double-current rectifier, shown in Fig. 4.

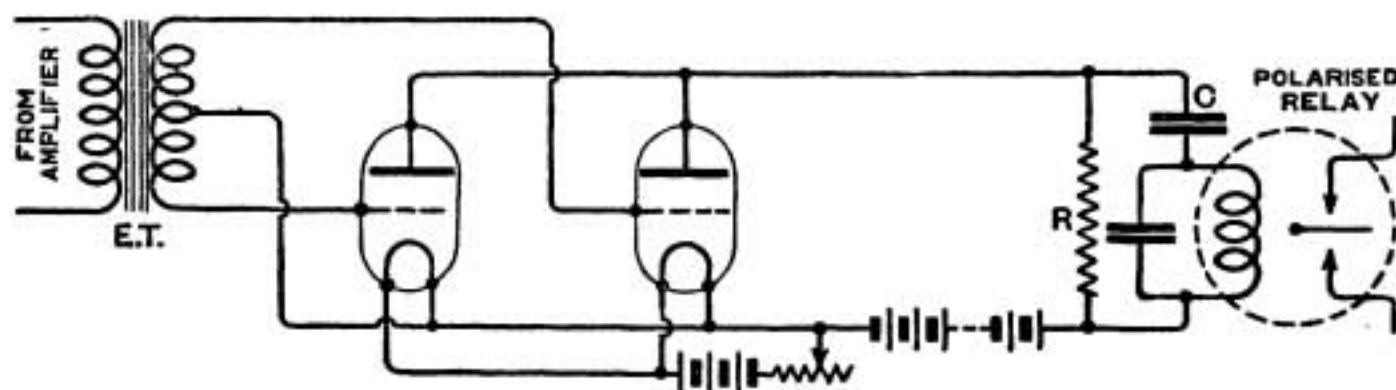

FIG. 4.

The grid battery is adjusted so that an E.M.F. in either direction in the transformer ET causes an increase in the anode current. The relay winding is only 50 ohms whereas the shunt R is 7,000 ohms, hence the receipt of a signal causes a rush through the relay winding to charge the condenser C; this throws the tongue over to marking; on the cessation of the signal, the condenser discharges and the tongue moves back to spacing. Other schemes are described in the article. Instead of an elevated aerial in some cases two closed frames at right angles are used connected to a goniometer. In the experiments between Berlin and Königsberg the transmitter was at Königswusterhausen, the receiver at Teltow, whilst the Wheatstone transmitter and inker were at the main telegraph office in Berlin, connection with which was obtained by superposition upon the telephone circuits. The speed obtained depended on the degree of interference, but reached a maximum of 300 letters a minute.

1066. APPARATUS FOR ALTERATION OF WAVELENGTH. E. F. Huth and S. Loewe. (*German Patent* 307713, January 16th, 1916. Patent granted October 7th, 1919. *Jahrbuch Zeitschrift für drahtlose Telegraphie*, 15, p. 346, April, 1920.)

An arrangement in which a variable condenser and a variometer are controlled by means of a single handle.

1067. TUNING DEVICE FOR WIRELESS TELEGRAPHY. E. F. Huth. (*German Patent* 307714, November 25th, 1917. Patent granted October 7th, 1919. *Jahrbuch Zeitschrift für drahtlose Telegraphie*, 15, p. 346, April, 1920.)

A variometer for use in the transmission and reception of sustained waves consisting of a short-circuited coil coupled to the main circuit. Comparatively large alterations in the position of the short-circuited coil produce only small variations in the main self-inductance.

1068. NOTE ON THE INPUT IMPEDANCE OF VACUUM TUBES AT RADIO FREQUENCY. J. Weinberger. (*Proceedings of the Institute of Radio Engineers*, 8, pp. 234—341, August, 1920.)

The high frequency input impedance of a triode valve (*i.e.*, impedance of the grid-to-filament path) for negative grid voltages is not infinite as the ordinary direct current characteristic would lead one to expect, but varies considerably with the frequency. Because of the considerable capacitative coupling between the grid-to-filament path and the plate-to-filament path the apparent input impedance is also found to be a function of the character of the output circuit. A substitution method of measuring the apparent input resistance for any particular tube is described. Using this method it was found with a Western Electric valve, Type D, that as the output resistance was varied from zero to 5 megohms the apparent input resistance varied from infinity down to a minimum of 50,000 ohms and then up to 170,000 ohms. An inductance inserted in the anode circuit produced a diminution of effective input impedance, while a capacitative output circuit produced neither a positive nor negative effect at the input terminals.

In the discussion L. M. Hull showed the deductions made from the experimental results to be considerably in error in that the input impedance is regarded as a pure resistance whereas Miller (see RADIO REVIEW Abstract No. 416, June, 1920) has shown that the input impedance of a tube having a pure resistance load in the anode circuit should be represented by a resistance in series with a capacity.

1069. EXPERIMENTS ON WIRELESS DIRECTION FINDING IN AIRCRAFT. R. Baldus and E. Buchwald. (*Jahrbuch Zeitschrift für drahtlose Telegraphie*, 15, pp. 214—236, March, 1920. *Science Abstracts*, 23B, pp. 399—400, Abstract No. 766, August 31st, 1920—Abstract.)

Further details of tests made at the military aerodromes at Döberitz and Lärz.* Signals were sent out from the aeroplane and picked up on a Bellini-Tosi type of receiving antenna. Tests were also made with horizontal cross receiving antennæ, the results being very similar.

1070. RADIO DIRECTION CHANGES AND VARIATIONS OF AUDIBILITY. C. Kinsley and A. Sobey. (*Proceedings of the Institute of Radio Engineers*, 8, pp. 299—325, August, 1920.)

Describes experimental work carried out with the aim of determining to what extent electromagnetic waves change their direction as measured by the radiogoniometer and to obtain the relation existing, if any, between changes of audibility and changes of direction. Using a radiogoniometer it has been found that the minima lie 90° from the direction of the transmitting station—using normal daylight conditions—even though the maximum vector does not lie along this direction, a typical example showing that where the angle between

* See RADIO REVIEW Abstract No. 672, August, 1920.

true direction and maximum vector was 10° the direction indicated by the minima observations was only thirty-five minutes in error. The audibility meter used consisted of an iron core inductive resistance in series with a high resistance telephone, shunted by a non-inductive resistance, the audibilities being computed by using the impedance of the telephone, and not the resistance, in the usual equations. It was found that during sunlight the direction measurements varied but little though they were extremely erratic during the night. In the case of transmitters employing an undamped wave of great wavelength more directional distortion is found than when a transmitting system using damped waves and a shorter wavelength is employed.

The changes in audibility are of much more frequent occurrence and are proportionally much larger than the changes in direction, while there appears to be no evident relation between audibility and direction changes. There is much evidence to support the view that the audibility changes follow a diurnal cycle as well as a seasonal one. Various theories to account for the observed phenomena are proposed, notably that in which reflection at the atmospheric "isothermal layer" (10 km high) is assumed.

1071. MEASUREMENT OF THE ELECTROMAGNETIC FIELD OF WAVES RECEIVED DURING TRANS-OCEANIC RADIO TRANSMISSION. G. Vallauri. (*Proceedings of the Institute of Radio Engineers*, 8, pp. 286—298, August, 1920.)

This article was first published in *L'Elettrotecnica*,* and its subject-matter has already been dealt with in the editorial article in the October issue of the RADIO REVIEW.† In the discussion of the paper as published by the Institute of Radio Engineers, Dr. Austin emphasises his belief that the Naval (Austin) formula would agree with the average current received at Leghorn from Annapolis with an error not much greater than 50 per cent. Fuller's formula is also stated to be probably in error on account of the assumption made in the experimental work that the received telephone current (in which a tikker was used) is proportional to the power in the antenna, whereas it is more nearly proportional to the received antenna current.

1072. ON THE PROPAGATION OF ELECTROMAGNETIC WAVES AROUND THE EARTH. B. van der Pol. (*Philosophical Magazine*, 40, p. 163, July, 1920.)

A short note pointing out an error in the earlier paper by the same author,‡ in connection with the comparison of the theoretical and observed received currents in radio transmission over long distances. This error reduces the discrepancy between the theoretical and observed values, but does not invalidate the author's previous conclusions.

1073. OBSERVATIONS ON RADIO TRANSMISSION PHENOMENA. (*Scientific American*, 123, p. 129, August 7th, 1920.)

Reference is made to an arrangement between the United States Bureau of Standards and the American Radio Relay League for the systematic observation of radio transmission phenomena as regards fading of signals and variation of signal strength with meteorological conditions.

1074. EXPERIMENTS ON THE FILTERING OUT OF THE HARMONICS FROM THE NAUEN SIGNALS. A. Meissner and K. W. Wagner. (*Jahrbuch Zeitschrift für drahtlose Telegraphie*, 15, pp. 200—214, March, and pp. 392—406, May, 1920. *Technical Review*, 6, p. 690, August 17th, 1920—Abstract. *Science Abstracts*, 23B, pp. 395—397, Abstract No. 760, August 31st, 1920—Abstract.)

The oscillations produced in the aerial by an arc, a Goldschmidt alternator, or an alternator

* See RADIO REVIEW Abstract No. 958, October, 1920, for references.

† RADIO REVIEW, 1, pp. 652—655, October, 1920.

‡ RADIO REVIEW Abstract No. 48, November, 1919.

with frequency doublers, always contain higher harmonics which produce interference when receiving by the heterodyne method other continuous wave stations working at a smaller wavelength. At the suggestion of Max Wien the authors carried out tests to get rid of the harmonics in the Nauen aerial. These were caused mainly by the magnetic phenomena in the doublers, but were not of sufficient magnitude compared with the fundamental to be detected on a wavemeter. The success of the various devices was tested at three receiving stations, 4, 30, and 200 kms away. The harmonics were all those of the main aerial frequency up to the ninth and all the odd ones of the two foregoing frequency steps up to the seventh. With increasing excitation the harmonics increased more rapidly than the main wave. As the result of a number of trials the arrangement adopted consisted of a condenser and inductance in parallel across the secondary terminals of the last transformer which are connected also to the antenna and earth. This circuit tuned to the aerial frequency offers a high impedance to the main frequency but a low impedance to other frequencies. In addition to this two circuits consisting of inductance and capacity in series, tuned to the frequencies of the two principal harmonics were connected between the same terminals, thus giving additional paths of low impedance to these harmonics. The antenna current was only decreased 3 per cent., but the harmonics were almost entirely removed.

Experiments were also made on an artificial antenna in the laboratories of Siemens and Halske to test the efficacy of inserting a filter between the transformer and the antenna. This filter consisted of two elements of an artificial line. This proved very successful in removing the harmonics and had the advantage of being independent of tuning; it was thus unaffected by variations of generator speed.

1075. VALVE AMPLIFYING CIRCUIT FOR WIRELESS TELEGRAPHY. C. LORENZ.
(German Patent 308411, December 18th, 1917. Patent granted October 10th, 1919. *Jahrbuch Zeitschrift für drahtlose Telegraphie*, 15, p. 165, February, 1920—Abstract.)

A retroactive circuit in which any number of tubes can function in parallel. The switches are so arranged that as the number of tubes in use increases the retroactive coupling becomes looser. See Fig. 5.

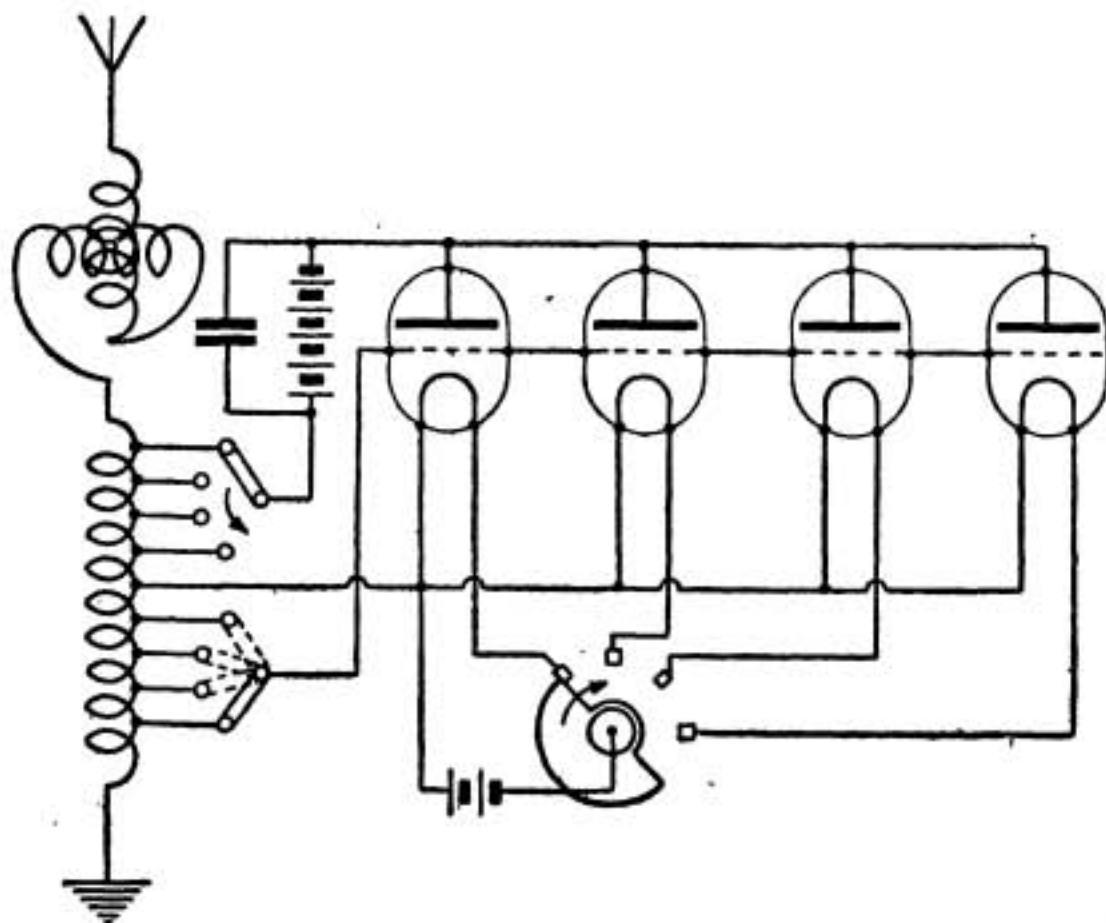

FIG. 5.

1076. RECEIVING CIRCUIT FOR SUSTAINED WAVES. Gesellschaft für drahtlose Telegraphie. (German Patent 308414, April 15th, 1914. Patent granted September 23rd, 1919. *Jahrbuch Zeitschrift für drahtlose Telegraphie*, 16, p. 232, September, 1920.)

A circuit (see Fig. 6) in which an alternating current produced in the anode circuit of the

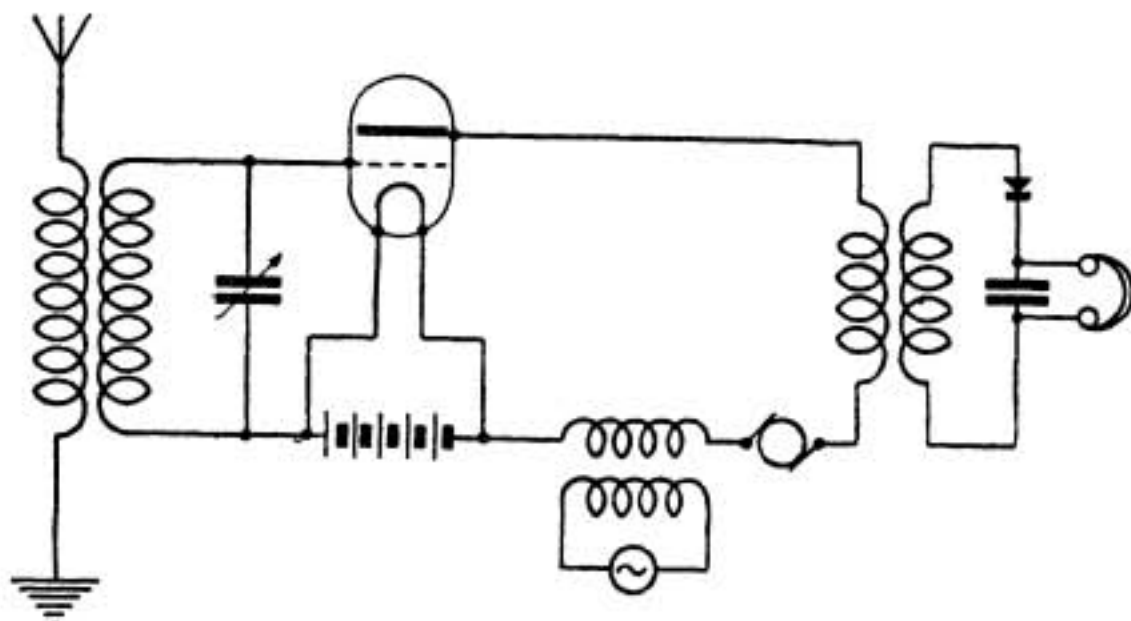

FIG. 6.

tube by an external heterodyne continues with the incoming oscillation to produce beats. Signals are received in an aperiodic detector circuit.

1077. RECEIVING HETERODYNE ARRANGEMENT. Société Française Radio-

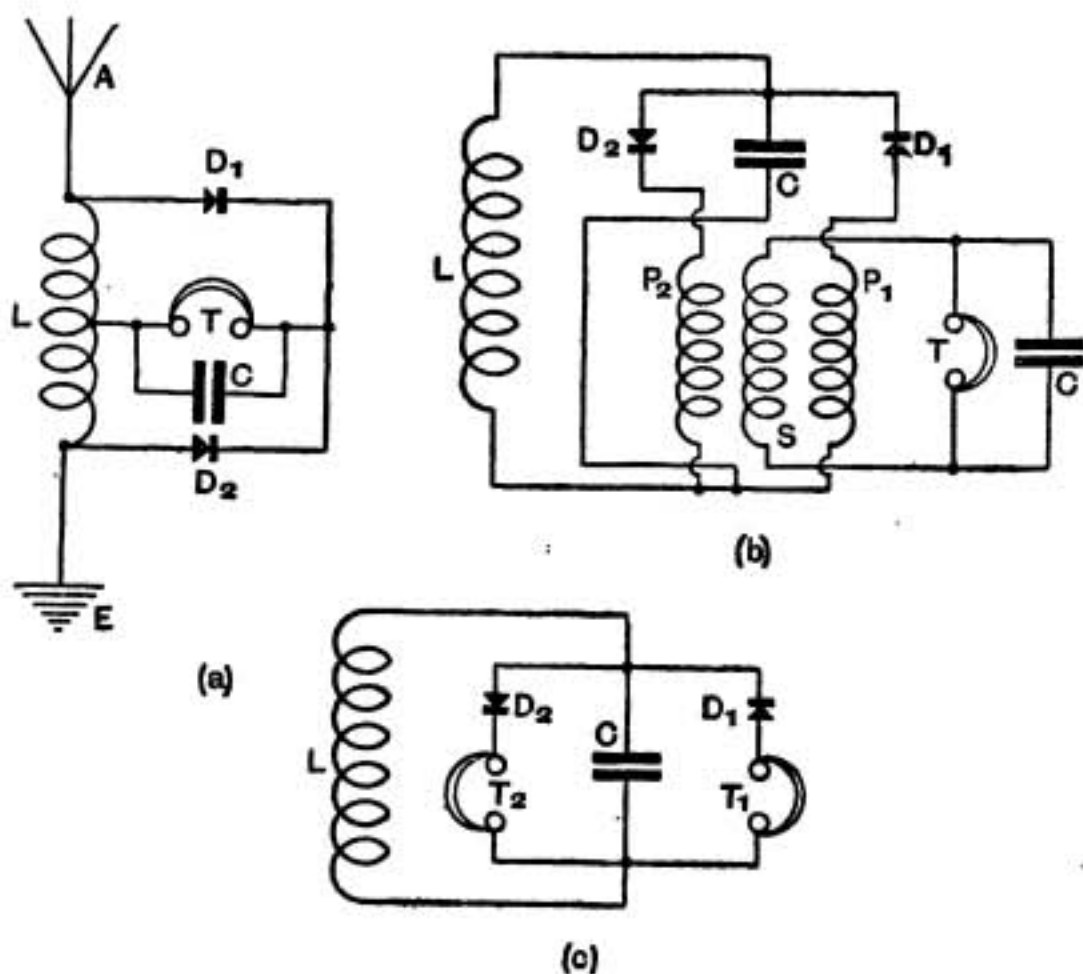

FIG. 7.

Électrique. (*French Patent* 502041, February 11th, 1915. Published May 1st, 1920.)

The invention relates to means for increasing the sensitiveness of receiving apparatus by employing two rectifying detectors of different polarities as for example in the manner indicated in Fig. 7 (a) in combination with a heterodyne arrangement. The specification shows various ways of arranging the two detectors. In Fig. 7 (c), L is the secondary inductance of the receiving circuit. In parallel with the condenser C are connected two detectors D_1 , D_2 , each in series with a telephone T_1 , T_2 respectively. By employing a transformer with windings P_1 , P_2 and a single secondary, a single telephone can be employed as shown in Fig. 7 (b). By combining this method with a heterodyne arrangement permitting the introduction of an auxiliary radio-frequency voltage in the circuit, so that the fraction of the current rectified is proportional to the voltage applied to the detectors, it is claimed that a sensitiveness can be obtained which is twice that of the usual arrangements.

1078. RECEPTION OF UNDAMPED WAVES: CONSTRUCTION OF A HETERODYNE. F. Duroquier. (*La Nature*, 48(2), Supplement p. 43, August 7th, 1920.)

The arrangement described constitutes a single valve receiver arranged for autodyne reception of continuous waves with an alternative of a crystal detector for spark reception.

1079. RECEPTION OF UNDAMPED WAVES. F. Duroquier. (*La Nature*, 48(2), Supplement pp. 3—4, July 3rd, 1920 and Supplement p. 12, July 10th, 1920.)

Simple constructional details are discussed for a tikker receiver for C.W. reception.

1080. MACHINES FOR CONSTRUCTING THERMOPHONES. A. M. van Doorn. (*U.S. Patent* 1338886 and 1338887, March 1st, 1919. Patent granted May 4th, 1920.)

Describes machinery to facilitate the construction of thermophone receivers.

1081. HOW WIRELESS SIGNALS ARE RECEIVED. C. G. Crawley. (*Discovery*, 1, pp. 206—209, July, 1920.)

The author gives a popular summary of the development of radio receivers from the coherer to the modern three-electrode valve. Some of the applications of valves to wireless telegraphy and to high speed working are also referred to.

1082. RECEIVING CIRCUIT FOR WIRELESS TELEGRAPHY. Gesellschaft für drahtlose Telegraphie. (*German Patent* 310732, October 17th, 1918. Patent granted September 20th, 1919. *Jahrbuch Zeitschrift für drahtlose Telegraphie*, 16, p. 233, September, 1920.)

An adaptation of the so-called "fly wheel" circuit in which the heating battery of a triode and its circuital elements are used as the counterpoise for the antenna.

1083. SENDING AND RECEIVING CIRCUIT FOR WIRELESS TELEGRAPHY. E. F. Huth. (*German Patent* 310702, October 14th, 1917. Patent granted October 7th, 1919. *Jahrbuch Zeitschrift für drahtlose Telegraphie*, 15, pp. 167—168, February, 1920—Abstract.)

A simple triode generating circuit which is transformed by means of a switch to a receiving circuit with a reduced anode voltage. Alteration of the coupling between the various circuits is thus avoided.

1084. RESONANCE WAVE COIL. G. O. Squier. (*Electrical World*, 76, p. 137, July 17th, 1920.)

Refers to the development of a resonance coil for radio reception which may be used either in conjunction with an ordinary aerial or as its own antenna. The coil has goniometric properties. See also RADIO REVIEW Abstract No. 854, September, 1920.

1085. THE USE OF ELECTRIC LIGHT MAINS FOR THE RECEPTION OF WIRELESS SIGNALS. M. Thiercelin. (*La Nature*, 48(2), Supplement p. 22, July 17th, 1920.)

A short note describing apparatus used for the reception of wireless signals using electric light wires for aerial, a small condenser being interposed between the power circuit and the receiving apparatus.

1086. AERIALS. R. O. Ranger. (*French Patent* 501746, July 18th, 1919. Published April 22nd, 1920.)

An arrangement of receiving antennæ is described in this specification such that the effects produced by a signal from a distant transmitting station are conveyed separately to a single receiving apparatus from a number of antennæ. The effects act collectively on this receiving apparatus independently of all relations between the wavelengths employed and the distances separating the aerials. In Fig. 8, T represents the transmitting station, and $A_1, A_2,$

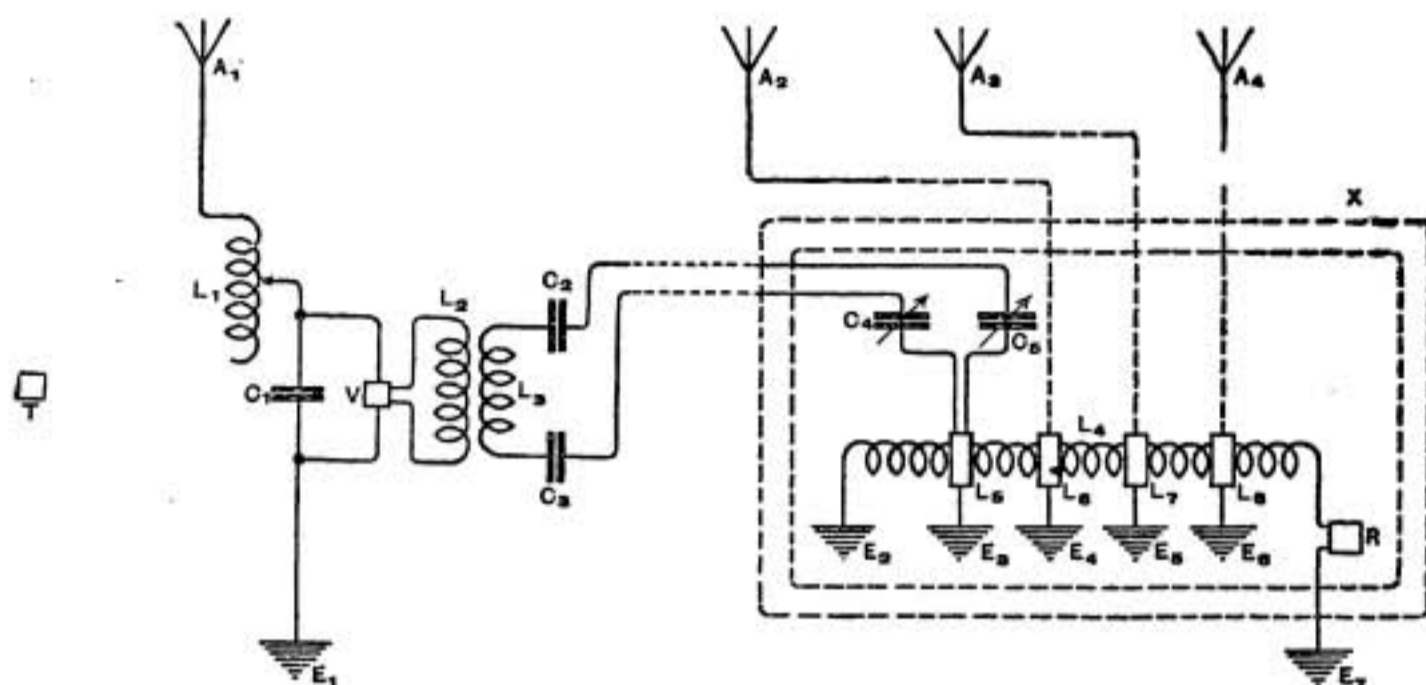

FIG. 8.

A_2, A_4 the separate receiving antennæ which may be separated at equal or other distances from one another and from the transmitting station. The antenna A_1 is connected to an inductance L_1 and thence to earth through the condenser C_1 . The terminals of this condenser are joined to a high frequency amplifier designated by V, and thence to the primary winding of the transformer L_2, L_3 . The secondary L_3 of this transformer is joined through the condensers C_2, C_3 to the receiving apparatus X. Two variable tuning condensers C_4, C_5 are also included in the circuit at the receiver. At the receiver, a coil L_4 is connected to earth through the receiving instrument R, and is provided with a number of movable coils L_6, L_7, L_8 , connected to their respective aerials in the manner indicated in the case of L_5 . The effects of the received signals from T are thus combined together and conveyed to R, the maximum effects being obtained by adjusting the positions of the sliding coils.

1087. WIRELESS TELEPHONY IN HOLLAND. (*Telefunken Zeitung*, 4, No. 20, pp. 74—75, May, 1920.)

A short description of two small stations erected for the Dutch postal authorities; one is at the Hague and sends weather reports to lightships, the other at Soesterberg.

1088. WIRELESS TELEGRAPHY IN FINLAND. (*Electrical Review*, 86, p. 721 June 4th, 1920.)

‡ Refers to the establishment of a network of wireless telegraph stations for press messages.

1089. A LARGE SWEDISH RADIO STATION. (*La T.S.F. Moderne*, 1, p. 64, May, 1920.)

Reference is made to a project for the establishment of a station in Sweden near Falkenberg for communication with the United States. The aerial is to be supported by towers 650 feet high. The wavelength is to be 17,000 metres and the station is to employ from 300 to 400 kW. It is hoped that it will be ready for operation in 1923.

1090. WIRELESS IN MESOPOTAMIA AND PERSIA. W. Wetzlinger. (*Telefunken Zeitung*, 4, No. 20, pp. 43—56, May, 1920.)

Some details and illustrations are given of the portable, and other stations, and of the ranges worked.

1091. CARNARVON RADIO STATION. (*Electrical Experimenter*, 7, pp. 778 and 826—827, December, 1919.)

An illustrated description abstracted from the *Wireless World*, 7, pp. 301—307, September, 1919.

1092. TROPICAL RADIOTELEGRAPH COMPANY'S STATIONS AND EQUIPMENT. (*Telegraph and Telephone Age*, 38, pp. 272—275, May 16th, 1920.)

A short illustrated description of the New Orleans and Swan Islands Stations and of some ship installations fitted by the Tropical Radiotelegraph Company.

1093. LONG DISTANCE RADIO COMMUNICATION IN CHILI. E. W. Fielding. (*Technical Review*, 6, p. 507, June 8th, 1920—Abstract.)

See also RADIO REVIEW Abstract No. 451, June, 1920.

1094. REMINISCENCES OF WIRELESS ON THE BLIMP PATROL. M. B. Egan. (*Wireless World*, 7, pp. 557—563, January, 1920.)

Some of the wireless apparatus used on anti-submarine patrol aircraft is described and illustrated.

1095. AN EXPERIMENTAL STATION. E. Ludwig. (*Wireless World*, 7, pp. 583—586, January, 1920.)

Constructional details are given.

1096. RADIO FOG SIGNALLING. (*Electrical Experimenter*, 7, p. 909, January, 1920.)

Some experiments carried out by the Bureau of Standards, Washington, and by the Bureau of Lighthouses, U.S.A., are referred to, relative to the use of radio signals from lighthouses in Chesapeake Bay. A rotating frame aerial and four-stage amplifier was used on the ship and it was found that at a distance of fifty miles the position of the ship could be determined to less than half-a-mile.

1097. THE NEW MEXICAN TELEFUNKEN STATION AT CHAPULTEPEC. (*Telefunken Zeitung*, 41, No. 20, pp. 19—22, May, 1920.)

An illustrated description of the station which has a 150—170 kW 500-cycle alternator, a 100,000 volt transformer and a quenched spark gap.

1098. TELEFUNKEN EXHIBITION. (*Telefunken Zeitung*, 2, No. 18, pp. 11—28, October, 1919.)

Description of an exhibition of Telefunken apparatus old and new, which has since been put on a permanent basis at the headquarters of the company in Berlin.

1099. THE ARCHITECTURE OF THE NAUEN STATION. H. Mathesius. (*Telefunken Zeitung*, 3, No. 17, pp. 33—45, August, 1919.)

A well-illustrated descriptive article.

1100. DUPLEX RECEIVING APPARATUS AT GELTOW. A. Esau. (*Telefunken Zeitung*, 17, pp. 75—78, August, 1919.)

A brief description of the station near Potsdam, which serves as the receiving station in the Nauen duplex system.

1101. MICA CONDENSERS FOR RADIO SETS. (*Electrical Experimenter*, 7, p. 781, December, 1919.)

Two patterns of enclosed radio transmitting condensers with mica dielectric are illustrated.

1102. THE DESIGN AND CONSTRUCTION OF CONDENSERS FOR RADIOTELEGRAPHY. P. Maurer. (*L'Électricien*, 51, pp. 278—279, July 1st, 1920.)

The author deals with the difficulty of constructing small receiving condensers to any given capacity, and refers to the advantages of series-parallel connection of small condenser units to obtain the desired capacity values.

1103. ELECTRIC CONDENSERS. W. Dubilier. (*British Patent* 141658, July 24th, 1919. Convention date, April 11th, 1919. Patent not yet accepted but open to inspection. *Wireless Age*, 7, pp. 19—20, June, 1920—Abstract.)

The construction of multi-plate condensers is described, in which the plates are formed of some hard material such as copper coated on both sides with a soft material such as lead foil which may be pressed into intimate contact with the irregularities of the dielectric sheets. The copper "core" to the plates enables greater conductivity to be obtained in the plates.

1104. ELECTRIC CONDENSERS. W. Dubilier. (*British Patent* 141690, April 1st, 1920. Convention date, April 11th, 1919. Patent not yet accepted but open to inspection. *Wireless Age*, 7, pp. 22—23, March, 1920—Abstract.)

The construction of condensers having a number of units in series is described, the terminal connections between the succeeding sections being arranged at various points round the block of sections so that the use of insulating barriers between them is avoided.

1105. ELECTRIC CONDENSER. E. A. Bayles. (*British Patent* 139694, May 23rd, 1919. Patent accepted March 11th, 1920.)

The arrangement of a battery of oil-immersed condensers in a containing tank is dealt with.

1106. AN EFFICIENT VARIABLE CONDENSER. G. W. Hale. (*Wireless World*, 7, pp. 630—632, February, 1920.)

Constructional details and dimensioned drawings are given.

1107. CONDENSERS AND RESISTANCES. (*La T.S.F. Moderne*, 1, pp. 56—58, May, 1920.)

Constructional details are given of simple forms of grid and intervalve coupling condensers and of grid and anode resistances for valve circuits.

1108. A WET COTTON GRID LEAK AND INTERVALVE RESISTANCE. E. W. Kitchin. (*Wireless World*, 8, pp. 265—266, July 10th, 1920.)

This article deals with some experiments on the use of a wet cotton thread for grid leaks and intervalve resistances for amplifiers. For a grid leak the cotton thread is attached to two copper wire terminals which are hermetically sealed into a rubber tube filled with distilled water; while for anode circuit resistances a loop of cotton may be suspended in a small hermetically sealed receptacle containing distilled water to maintain the cotton in a wet condition.

1109. A NEW TYPE OF HIGH RESISTANCE. F. Skaupy and H. Ewest. (*Zeitschrift für technische Physik*, 1, pp. 167—169, August, 1920.)

Graphite is deposited on spirals of insulating material, generally glass, which are then

preferably enclosed in a glass bulb filled with hydrogen because of its superior heat conduction. The bulb is fitted with an Edison socket like a glow lamp or fitted with a metal clip at each end for convenient insertion in a socket. The results of tests on three resistances of $3.6.10^3$, 14.10^3 and 33.10^3 ohms respectively, showed that with currents of 5, 4 and 2 milliamperes the resistances immediately took up their final value, whereas with currents of 42, 21 and 9 milliamperes an interval of from 7 to 15 minutes elapsed before the steady values were attained, the resistances falling from 3 to 9 per cent. of their initial value. On cutting off the current they regain their initial value. When tested with very small currents they showed no signs of troublesome contact resistance.

They can stand a continuous load of 1 watt per square centimetre of graphite surface. They are being made in standard sizes for values ranging between 1,000 and 500,000 ohms.

1110. TELEGRAPHING BY INVISIBLE LIGHT BEAMS. H. Gernsbach and H. W. Secor. (*Electrical Experimenter*, 7, p. 1126, March, 1920.)

Some editorial notes referring to the article by H. de Gallaix on telegraphy with infra-red rays (see Abstract No. 1019, October, 1920). It is mentioned that successful transmission has been obtained by this means between Sandy Hook and the Woolworth Building in New York City, the distance being eighteen miles.

1111. TALKING OVER A SUNBEAM. A. O. Rankine. (*Electrical Experimenter*, 7, pp. 1263 and 1315—1316, April, 1920.)

A summary of some of the methods of photophony, and of the author's arrangements.*

1112. SIGNALLING BY INVISIBLE RAYS. (*Engineering*, 109, pp. 797—798, June 11th, 1920.)

A brief *résumé* of maritime development in signalling by ultra-violet and infra-red rays. The researches of Case, Coblentz and Professor Wood are briefly summarised.

1113. THERMO-ELECTRICITY AND SOME OF ITS APPLICATIONS. P. R. Coursey. (*Wireless World*, 8, pp. 181—183, June 12th, 1920.)

The use of thermopiles for telephony by light and heat rays is referred to in this article.

1114. SUBMARINE SOUND RECEIVERS AND TRANSMITTERS. M. I. Pupin. (*British Patents* 139496 and 139497, February 25th, 1920. Convention date, February 4th, 1919. Patent not yet accepted but open to inspection.)

Apparatus is described for submarine sound signalling using high frequency impulses (of the order of 100,000 \sim) using a condenser transmitter and a crystal receiver operated by changes of pressure (Piezo-electric effect).

1115. MODERN MARINE PROBLEMS IN WAR AND PEACE. C. V. Drysdale. (*Journal of the Institution of Electrical Engineers*, 58, pp. 572—597, July, 1920. *Engineering*, 110, pp. 484—486, October 8th, pp. 521—523, October 15th, and pp. 552—554, October 22nd, 1920—Abstract.)

Report of the Eleventh Kelvin Lecture delivered before the Institution of Electrical Engineers on April 15th, 1920. The paper deals with the wartime research work carried out by the Admiralty departments and is divided into four sections dealing respectively with Submarine Detection, Defence and Destruction, Navigational Applications, and General Scientific Research. The various types of hydrophones are fully described and also the "leader" cable and other aids to navigation. Appendices deal with the Theory of Acoustic Transmission; the Theory of Three-station Sound Ranging; Theory of the Propagation of Electromagnetic Waves in a Conducting Isotropic Medium (such as sea water); the Transmission of Alternating Currents through Large Conductors, and the Current and Field Distribution in a Conducting Medium surrounding a Cable carrying an Alternating Current.

* See RADIO REVIEW Abstracts No. 178, January, 1920, No. 255, March, 1920, and No. 731, August, 1920.

1116. THE THEORY OF RECEIVERS FOR SOUND IN WATER. H. A. Wilson. (*Physical Review*, 15, pp. 178—205, March, 1920. *Science Abstracts*, 23A, p. 397, Abstract No. 1000, July 31st, 1920.)

A mathematical paper divided into five sections dealing respectively with: (1) Single receivers; (2) two receivers as used for direction finding; (3) multiple receivers; (4) lines of receivers; (5) receivers distributed over large areas.

1117. SWIVELLING BRACKETS FOR MOUNTING ELECTRIC GENERATORS ON AIRCRAFT. F. J. Hooper. (*British Patent* 138212, March 24th, 1919. Patent accepted February 5th, 1920.)

Wind driven dynamos are mounted on aircraft by means of a swivelling bracket so that they may be brought to different angles with respect to the air stream in order to regulate their speed.

1118. AIRCRAFT RADIO. (*La Nature*, 48, pp. 156—165, April 10th, 1920. *Technical Review*, 6, p. 549, June 22nd, 1920—Abstract.)

A general article describing in detail the state of knowledge with regard to aircraft radio apparatus prior to the war and of the development of the various branches of radio work in aircraft during the war. Illustrations are given of some of the apparatus used both for telegraphy and telephony, while the installations used for direction finding are also dealt with.

1119. MAN, AIR AND ETHER—THE FIRST LONDON-PARIS FLIGHT ON A HANDLEY-PAGE COMMERCIAL MACHINE FITTED WITH WIRELESS TELEPHONY. H. C. van der Velde. (*Wireless World*, 8, pp. 119—124, May 15th, 1920. *Technical Review*, 6, p. 589, July 6th, 1920—Abstract.)

An account of the trip from London to Paris and back on March 4th, 1920, of a Handley-Page machine carrying a wireless telephone installation. Some particulars as to the ranges obtained are given throughout the article, which is also accompanied by a photographic illustration of the gear.

1120. AIRCRAFT WIRELESS SETS: THE 54A SPARK TRANSMITTER. J. J. Honan. (*Wireless World*, 7, pp. 512—514, December, 1919.)

An illustrated description.*

1121. HOW AEROPLANES ARE NAVIGATED BY WIRELESS. R. Keen. (*Wireless World*, 7, pp. 578—582, January, 1920.)

This paper summarises the difficulty of D.F. work on aircraft.†

1122. WIRELESS SERVICE ON AIRCRAFT ROUTES. (*Wireless World*, 8, pp. 237—240, June 26th, 1920. *Technical Review*, 6, pp. 724—725, August 31st, 1920.)

The various applications of wireless telephony in aircraft are discussed.

1123. THE ELIMINATION OF MAGNETO DISTURBANCE IN THE RECEPTION OF WIRELESS SIGNALS ON AIRCRAFT. J. Robinson. (*Science Abstracts*, 23B, pp. 165—166, Abstract No. 334, March, 1920—Abstract.)

See RADIO REVIEW, 1, pp. 105—110, December, 1919, for original paper.

1124. "THE ELIMINATION OF MAGNETO DISTURBANCE." L. J. Voss. (*Radio Review*, 1, pp. 258—259, February, 1920.)

Correspondence relative to the paper by J. Robinson with the above title.‡

1125. HELLO, MARS. H. W. Secor. (*Electrical Experimenter*, 7, p. 48, April, 1920.)

* See also RADIO REVIEW Abstract No. 258, March, 1920.

† See also RADIO REVIEW Abstract No. 361, May, 1920.

‡ RADIO REVIEW, 1, pp. 105—110, December, 1919.

1126. INSULATING MATERIALS. (*Telegraph and Telephone Age*, 38, pp. 73—74, February 1st, 1920.)
A *resumé* of the chief properties of electrose, fibre, and the bakelite products as insulating materials, and also in connection with their use in radio work.
1127. EARLY EXPERIENCES OF A WIRELESS AMATEUR. W. J. Fry. (*Wireless World*, 7, pp. 602—604, January, 1920.)
Some early experiments with coherers and similar apparatus are described.
1128. TRAINING OF AN R.A.F. WIRELESS OPERATOR. M. B. Egan. (*Wireless World*, 7, pp. 621—627, February, 1920.)
The equipment of Flowerdown Training Camp, Winchester, is discussed and illustrated.
1129. M. BRANLY'S DONATION TO THE "POSTES ET TÉLÉGRAPHES" MUSEUM. (*Annales des Postes, Télégraphes et Téléphones*, 8, pp. 651—653, December, 1919. *Revue Générale de l'Électricité*, 7, p. 240, February 14th, 1920—Abstract.)
The early forms of Branly's coherers included in this donation are briefly described and illustrated.
1130. NAVAL OBSERVATORY TIME SIGNALS. (*Scientific American*, 122, p. 417, April 17th, 1920.)
Some of the results of observations on the accuracy of wireless time signals are quoted. The majority of the errors centred round 0.01 second. Figures for the transmission lags of some American stations are also given.
1131. NAUEN AFTER THE WAR. (*Telefunken Zeitung*, 4, No. 20, pp. 12—14, May, 1920.)
Deals with the radio traffic between Germany and U.S.A.
1132. WIRELESS TELEGRAPHY IN NORTH AMERICA. (*Elektrotechnische Zeitschrift*, 41, p. 416, May 27th, 1920.)
Refers to the signalling ranges of some of the high power American stations.
1133. ELECTRICAL ENGINEERING—WIRELESS. (*The Times Engineering Supplement*, No. 543, p. 29, January, 1920.)
Very brief notes *re* wireless progress during 1919.
1134. MAGNETIC STORMS AS AFFECTING OCEAN TELEGRAPH CABLES. E. Raymond-Barker. (*Electrical Review*, 86, p. 293, March 5th, 1920.)
Refers to the application of wireless to giving warnings of magnetic storms.
1135. TIME TABLE OF THE PRINCIPAL RADIOTELEGRAPHIC TRANSMISSIONS. F. Duroquier. (*La Nature*, 48, Supplement p. 9, January 10th, 1920. *Revue Générale de l'Électricité*, 7, p. 54B, February 21st, 1920.)
The table includes particulars as to the messages sent (press, time-signals, etc.) and states the wavelength and whether damped or continuous waves.
1136. WIRELESS TELEGRAPHY AND THE UNIFICATION OF TIME. (*L'Électricité*, 2, p. 1, February 15th, 1920.)
Suggests the utility of wireless signals for securing agreement in clock readings at railway stations.
1137. WIRELESS IN WARFARE. (*Telegraph and Telephone Journal*, 6, pp. 164—166, July, 1920.)
Describes the methods of wireless signalling from aircraft used for directing artillery fire.

1138. INTER-IMPERIAL COMMUNICATION THROUGH CABLE, WIRELESS AND AIR. C. Bright. (*Génie Civil*, 76, p. 284, March 13th, 1920; *Revue Générale de l'Électricité*, 7, p. 196D, June 19th, 1920—Abstract.)
See RADIO REVIEW Abstract No. 204, February, 1920, for reference to the original paper.
1139. SENSITIVE APPARATUS FOR THE MEASUREMENT OF ALTERNATING CURRENTS. H. Abraham, E. Bloch and L. Bloch. (*Zeitschrift für Instrumentenkunde*, 40, p. 79, April, 1920—Abstract.)
See RADIO REVIEW Abstract No. 5, October, 1919.
1140. OLD AND MODERN TELEPHONES. W. J. Fry. (*Wireless World*, 8, p. 167, May 29th, 1920.)
Some historic telephone receivers are illustrated in this short note.
1141. "TEXT-BOOK ON WIRELESS TELEGRAPHY." Rupert Stanley; R. Whiddington. (*Radio Review*, 1, pp. 418—420, May, 1920.)
Correspondence relative to the above book by R. Stanley.*
1142. SPEAKING ON A BATTLESHIP TO A CROWD IN NEW YORK CITY. (*Scientific American*, 122, p. 601, May 29th, 1920.)
Describes a recent experiment in which speech by Mr. Daniels from the *Pennsylvania* was rendered audible to a crowd in New York City. The constructional arrangement of the loud speaking telephone that was used is also given.
1143. THE USE OF A VALVE AMPLIFIER AND TELEPHONE FOR THE DETECTION OF α AND β PARTICLES FROM RADIOACTIVE BODIES. M. Holweck. (*Revue Générale de l'Électricité*, 7, p. 713, May 29th, 1920.)
Abstract of paper read before the Société Française de Physique.
1144. WIRELESS TELEGRAPHY IN THE RED SEA DURING THE WAR. G. Montefinale. (*Wireless World*, 7, pp. 679—683, March, 1920.)
1145. THE DANGER OF HERTZIAN WAVES. (*La Nature*, 48, pp. 252—253, May 15th, 1920.)
Briefly describes some experiments to test the possibility or otherwise of combustion being produced by sparks set up by Hertzian waves.
1146. HIGH FREQUENCY MULTIPLEX TELEPHONY AND TELEGRAPHY. H. Fassbender and E. Habann. (*Science Abstracts*, 23B, pp. 106—107, Abstract No. 201, February, 1920—Abstract. *Electrical World*, 76, p. 86, July 10th, 1920—Abstract.)
See RADIO REVIEW Abstract No. 322, April, 1920.
1147. GEORG GRAF VON ARCO. (*Telefunken Zeitung*, 3, No. 17, pp. 5—19, August, 1919.)
A biographical notice of Count von Arco, who with Slaby founded what afterwards developed into the Telefunken Company.
1148. ÆTHER. P. R. Coursey. (*Wireless World*, 8, pp. 37—40, April 17th, 1920. *Technical Review*, 6, p. 467, May 25th, 1920—Abstract.)
A summary of some of the early theories of the æther and of some of the known facts relative to its properties. An "æther spectrum" is included covering the range of frequencies from 10 to 10^{20} per second with the positions of various known waves marked on the scale. A brief reference is also made to some of Sir J. J. Thompson's recently expressed views on the relation between æther and matter and on the mechanism of radiation.

* See review in RADIO REVIEW, 1, pp. 252—253, February, 1920.

1149. WIRELESS TELEGRAPHY. (*Nature*, 105, p. 17, March 4th, 1920.)
A brief note *re* wartime advances.

1150. HIGH FREQUENCY ELECTRIC SIGNALLING. L. N. Brillouin. (*British Patent* 138610, January 31st, 1920. Convention date, January 31st, 1919. Patent not yet accepted but open to inspection.)

Arrangements are described for signalling along wires using high frequency oscillations, with the oscillation source placed approximately at the centre of the line wires.

1151. ASTRONOMICAL ARRANGEMENTS BY WIRELESS TELEGRAPHY. Kobold. (*Nature*, 105, p. 403, May 27th, 1920.)

Arrangements are referred to for the distribution of astronomical information from the Nauen Station.

1152. THE LIFE AND WORK OF LORD KELVIN. E. Picard. (*Revue Scientifique*, 58, pp. 193—207, April 10th, 1920.)

A long summary of Lord Kelvin's scientific work and some of the theories proposed by him dealing with the ether, etc.

1153. A DIRECT CURRENT TRANSMITTER. L. M. Cockaday. (*Electrical Experimenter*, 7, p. 1282, April, 1920.)

Describes a transmitter using a rotary gap and a synchronous contact maker for producing the oscillations.*

1154. INTERPLANETARY WIRELESS. P. R. Coursey. (*Wireless World*, 8, pp. 1—7, April 3rd, 1920. *Technical Review*, 6, p. 467, May 25th, 1920—Abstract. *L'Elettrotecnica*, 7, p. 209, April 25th, 1920—Abstract.)

A critical discussion of the so-called messages from Mars, etc., and of the possibilities of wireless signalling between planets.

1155. RESEARCH FOR THE WIRELESS AMATEUR. W. T. Ditcham. (*Wireless World*, 8, pp. 113—116, May 15th, 1920.)

The author passes in review some of the lines upon which radio research may usefully be carried out. These include especially improvements in valves, C.W. receivers, X-stoppers, radiotelephone apparatus and auxiliary instruments generally.

1156. MAGNETIC STORMS. L. Pyle. (*Electrical Experimenter*, 7, pp. 876 and 920 and 922—924, January, 1920.)

The effect of sun spots and meteorological conditions upon the magnetic state of the earth is discussed and a number of magnetograph records are given.

1157. THE ROMANCE OF INVENTION. XIII. GENERAL G. O. SQUIER. C. H. Claudy. (*Scientific American*, 122, p. 620, June 25th, 1920.)

A brief *resumé* is given of General Squier's work on wired wireless and of his development of Signal Corps radio work.

1158. AN ANEMOMETER EMPLOYING ELECTRIC OSCILLATIONS. E. Rothe. (*Comptes Rendus*, 170, pp. 1197—1198, May 17th, 1920.)

The application of a small radio transmitter to an anemometer mounted in a small captive balloon or kite is described, so that its indications may be electrically transmitted to the ground using only a single conductor which serves as the mooring wire for the balloon. The indications are received on ordinary radio-receiving apparatus located on the ground, and connected or coupled to the mooring wire.

* See also RADIO REVIEW Abstract No. 111, January, 1920, for a further reference to this arrangement.

1159. MULTIPLEX TELEGRAPHY AND TELEPHONY BY HIGH FREQUENCY CURRENTS ON WIRES. (*Telefunken Zeitung*, 4, No. 20, pp. 5—7, May, 1920.) Also HIGH-FREQUENCY TELEPHONE EXCHANGE. P. Schwarzhaupt. (*Telefunken Zeitung*, 4, No. 20, pp. 7—11, May, 1920.)

In Germany high frequency telephony over wires has been in use for some months over an experimental line. The methods are those of wireless telephony, both for transmission and reception.

1160. THE TELEPHONIC AND RADIOTELEGRAPHIC ADMINISTRATION IN GERMANY. (*Annales des Postes, Télégraphes et Téléphones*, 9, pp. 31—36, March, 1920. *Technical Review*, 6, p. 506, June 8th, 1920—Abstract.)

A report of the Mission du Service d'Études et de Recherches Techniques issued February, 1920, and discussing the condition of the telephone system, etc., in Germany. Reference is made to the use of wired-wireless methods of communication between Berlin and Hanover and between Berlin and Frankfort. It is stated that the speech is better over the high frequency circuit than over the ordinary apparatus. As regards radiotelegraphy low power valve sets are being developed and the tendency is to replace all spark stations by C.W. apparatus.

1161. WIRELESS TRANSMISSION OF POWER. T. W. Benson. (*Electrical Experimenter*, 7, pp. 1118—1119, March, 1920.)

A suggestion for the transmission of high-frequency energy from place to place utilising the upper ionised layers of the atmosphere and ionised searchlight beams to make connection to them.*

1162. NEW TECHNICAL DEPARTMENT OF THE GERMAN TELEGRAPH ADMINISTRATION. (*Elektrotechnische Zeitschrift*, 41, p. 677, August 26th, 1920.)

On account of the continual growth of the wireless system and of the use of high frequency telegraphy and telephony along wires in the Imperial Telegraph Department, special courses of instruction have been instituted for those higher and middle grade employees who are considered suitable for this new branch. In future all new entries to these grades will be instructed in wireless telegraphy in the same way as they are at present instructed in the other branches of telegraphy and telephony.

1163. WIRELESS SAFETY DEVICE FOR MOVING TRAINS. (*Elektrotechnische Zeitschrift*, 41, p. 573, July 22nd, 1920.)

A wireless device has been devised and tested by the Telefunken Co. for drawing the attention of the engine driver to any signal set at danger. The locomotive carries a valve transmitter, the oscillations of which prevent the operation of a lamp and buzzer. If the signal is set against the train, a loop on the permanent way is closed; this abstracts so much energy from the oscillatory circuit that the lamp and buzzer are set in operation. Very few details are given in this note.

1164. MERCHANT SHIPPING WIRELESS TELEGRAPHY RULES. (*Electrician*, 85, p. 819, August 13th, 1920. *Electrical Review*, 87, p. 178, August 6th, 1920.)

Extracts are given from the new rules issued by the Board of Trade † and to come into force on September 3rd, relating to the installation of wireless apparatus on merchant vessels and of the auxiliary apparatus required in conjunction with it. Clauses are also included relative to the use of automatic apparatus for indicating incoming distress calls.

* See RADIO REVIEW Abstracts Nos. 701 and 702, August, 1920.

† Statutory Rules and Orders, No. 976, 1920 (London: H.M. Stationery Office, pp. 5. Price 3d. net).

1165. EIFFEL TOWER WIRELESS TIME SIGNALS. R. A. Samson. (*Nature*, 105, p. 268, April 29th, 1920.)

Particulars are given of the revised programme for the transmission of "scientific" time signals from the Eiffel Tower. Additional sets of signals are now being sent at 10.30 a.m. (G.M.T.) and 11 p.m. (G.M.T.). These additional signals are sent with a musical note. The reference numbers referring to them are designated ML and are sent after the 11.45 signals together with the reference numbers for the 11.30 series, the latter being designated by the letters RF.

1166. THE METEOROLOGICAL BULLETIN OF THE BRITISH AIR MINISTRY. (*La T.S.F. Moderne*, 1, pp. 47—50, May, 1920.)

Particulars are given of the times of transmission, the wavelength and the codes used for these messages. Brief reference is also made to the two undamped wave transmitters installed at the Air Ministry Station in London, one of which has a range of 100 km and the other one of 2,400 km.

1167. THE EIFFEL TOWER TIME SIGNALS. (*Wireless World*, 8, p. 138, May 15th, 1920.)

Two charts are given of the time signals sent on the old and new systems.

1168. EIFFEL TOWER WEATHER REPORTS. (*Wireless World*, 8, pp. 175—176, May 29th, 1920.)

Particulars are given of the codes used for the meteorological reports transmitted from the Eiffel Tower three times daily.

1169. TIME SIGNALLING STATIONS. (*Wireless World*, 8, pp. 273—274, July 10th, 1920.)

A list of stations transmitting time signals in the various countries of the world, giving call letters, wavelengths, and times of transmission.

1170. WEATHER BULLETINS. (*Admiralty Notice to Mariners*, No. 703, 1920. *Wireless World*, 8, pp. 278—279, July 10th, 1920.)

A list is given of stations in the various countries of the world transmitting meteorological messages. The call letters, wavelengths, and times of transmission are given.

1171. METEOROLOGICAL SIGNALS OF THE EIFFEL TOWER. (*La T.S.F. Moderne*, 1, pp. 18—24, April, 1920.)

The signalling code used for the meteorological information sent out daily from the Eiffel Tower is set out in detail.

1172. WEATHER CHARTS BY WIRELESS. (*Flight*, 12, pp. 970 and 977, September 9th, 1920.)

Particulars are given of the revised scheme of meteorological reports issued by radiotelegraphy from the Air Ministry and from Aberdeen wireless stations. A list is given of the places from which reports are obtained and the code used for the signalling is also indicated.

1173. A METHOD OF AMPLIFYING ELECTRICAL VARIATIONS OF LOW FREQUENCY. W. H. Eccles and F. W. Jordan. (*Electrician*, 85, p. 176, August 13th, 1920.)

In order to extend the range of frequencies over which a given triode amplifier may be operated, the authors propose to amplify low frequency alternating currents (such for example as speech currents) by impressing them upon a high frequency carrier oscillation, which may be subsequently amplified by means of any ordinary form of radio frequency amplifier. One proposed arrangement of circuit is indicated in Fig. 9, which shows a three-electrode valve V, with the low frequency currents to be amplified impressed upon its anode circuit at T₁. The valve is arranged to generate the carrier frequency oscillations by means of the tuned circuit LC, and the reaction M on to the grid circuit. The modulated radio frequency currents may be taken off from the terminals A₁ and A₂ and thence led to the terminals of the amplifier arranged for high frequency amplification. Several other arrangements are possible by using the valve shown merely as a modulating valve, and impressing upon it both the high

and the low frequency currents. The chief advantage of the method lies in the possibilities of increasing the amplification by means of resonance while avoiding distortion of the low frequency currents. It is claimed also that valve noises are reduced as compared with an ordinary low frequency amplifying arrangement.

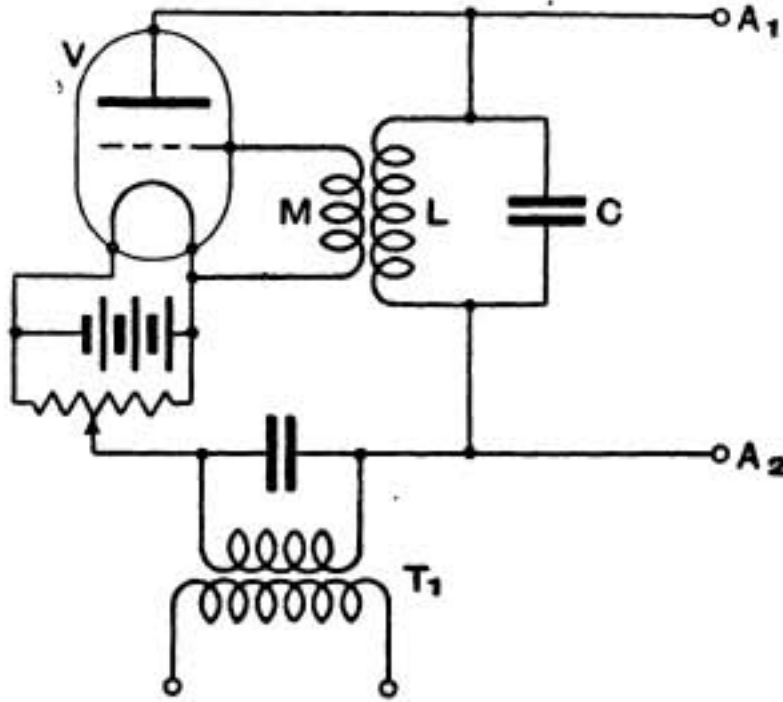

FIG. 9.

1174. MULTI-STAGE VALVE AMPLIFIERS. M. I. Pupin. (British Patent 139494, February 25th, 1920. Convention date, February 4th, 1918. Patent not yet accepted but open to inspection.)

The essential feature of the arrangement described in this specification is the use of a filtering circuit between successive groups of amplifying valves. Referring to Fig. 10, $V_1 V_2 V_3$ and V_4 are four amplifying valves coupled together with the usual arrangement of resistance capacity couplings $R_1 C_1, R_2 C_2, R_3 C_3, R_4 C_4$. Of these the first three valves are preferably of high internal resistance while V_4 is of low internal resistance. The resistance R_4 should be of less value than $R_1 R_2 R_3$ and be approximately equal to the internal resistance of V_4 . The filtering circuit proper consists of condensers $C_5 C_6 C_7 C_8$ and leak resistances $R_5 R_6 R_7 R_8$ which are all joined to earth at E_2 . The point G should be joined to the input grid of a second

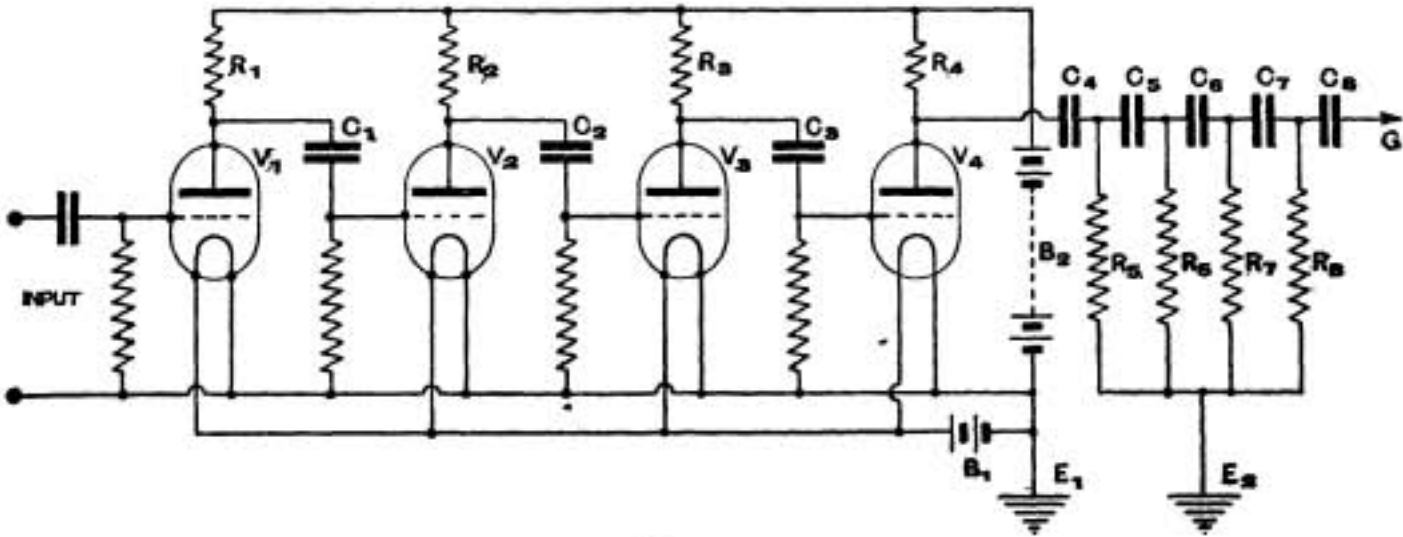

FIG. 10.

group of valve amplifiers of exactly similar nature to $V_1 V_2 V_3 V_4$. Any number of groups of valves may be connected together by such an arrangement. If low resistance valves are used throughout, the condensers $C_4 C_5 C_6 C_7 C_8$ may with advantage be replaced by resistances, and resistances $R_5 R_6 R_7 R_8$ replaced by inductances. The actual filtering circuit is such as to destroy the reaction between the groups of amplifiers as regards internal and external disturbances but yet to allow the passage of the desired wave signals.

1175. THERMIONIC VALVE AMPLIFIERS. G. F. Partridge and B. S. Smith. (*British Patent* 137876, November 13th, 1918. Patent accepted January 29th, 1920.)

To a usual arrangement of resistance capacity coupled multi-stage valve amplifiers a special addition is made to prevent howling when more than three valves are employed. This modification is introduced in the grid of the third valve if the amplifier contains more than four or five stages, or in the grid of the fourth valve if the amplifier has six stages. The modification consists of a variable condenser placed in parallel with the grid leak of the valve in question, the resistance of this leak being much less than in the case of the other valves. The arrangement is described as being especially of use with low frequency amplifiers.

1176. VALVE AMPLIFIERS AND MEDICAL SCIENCE. J. Scott-Taggart. (*Electrician*, 85, p. 62, July 9th, 1920.)

The writer refers to some experiments in connection with the use of triode amplifiers in connection with microphonic stethoscopes for medical work. It is suggested that this provides a field for further research.

1177. THE USE OF AMPLIFIERS FOR LOCATING FAULTS IN ARMoured CABLES. G. Rosche. (*L'Électricien*, 51, pp. 277—278, July 1st, 1920.)

Describes the use of three-electrode valve amplifiers used in conjunction with movable earth connections for locating leakage currents from cables.

1178. THE MAGNAVOX. (*Science and Invention*, 8, p. 408, August, 1920.)

A description of the Magnavox Loud Speaking Telephone comparing it with an ordinary type of receiver. A sectional diagram is given of the construction of the apparatus in which the diaphragm is actuated by a coil moving in a magnetic field and not by a direct pull from a fixed magnet as in an ordinary telephone receiver.

1179. HIGH FREQUENCY MULTIPLEX TELEPHONY AND TELEGRAPHY ALONG WIRES (Part II).* H. Fassbender and E. Habann. (*Jahrbuch Zeitschrift für drahtlose Telegraphie*, 15, pp. 407—423, May, 1920. *Science Abstracts*, 23B, Abstract No. 689, pp. 357—358, July 31st 1920—Abstract. *Elektrotechnische Zeitschrift*, 41, p. 572, July 22nd, 1920—Abstract.)

A discussion of the applicability of the ordinary telephone formulæ for calculating the attenuation constant of a line to the case of very high frequencies, in view of the variation of the resistance, inductance, capacitance, and leakage with the frequency.

1180. WIRED WIRELESS TELEGRAPHY. (*La Nature*, 48(2), pp. 93—94, August 7th, 1920.)

A short *resumé* of some of G. O. Squier's work on Wired Wireless.

1181. INTERPLANT TELEPHONE COMMUNICATION ESTABLISHED OVER HIGH TENSION WIRES. (*Electrical World*, 76, p. 141, July 17th, 1920. *Technical Review*, 6, p. 788, September 28th, 1920—Abstract.)

Refers to an installation of wired wireless telephone over the high tension power lines of the American Gas and Electric Company. Range of transmission about 21 miles.

* See RADIO REVIEW Abstract No. 322, April, for Part I.

2. Books.

ÉLÉMENTS DE TÉLÉGRAPHIE SANS FIL PRATIQUE. By F. Duroquier.
(Paris: *H. Dunod*. Second edition, 1920. Pp. 130. Price, 6 fr. 75.)

This is a small handbook for the French amateur radiotelegraphist. It is divided into three parts, the first treating of elementary principles, the second the construction and installation of apparatus, and the third, entitled "Applications of Wireless Telegraphy," gives information about time and meteorological radio services, the Morse code and similar subjects.

In the first part, the principle of action of various instruments is described, such as the induction coil, coherer, electrolytic, crystal, and other detectors, together with the simpler circuits for transmission and reception. Included among the latter are several diagrams with the detector inserted in series with the aerial, which might just as well be omitted since they are far inferior to the more usual circuits, and are likely to give erroneous impressions as to sensitivity of detectors, etc., to the amateur who is taking up the subject for the first time. The advantage of coupled circuits is pointed out and there is a short description of a three-valve note magnifier.

The description, whilst very elementary, is, in general, correct. The author, however, wrongly attributes the invention of the aerial to Sir Oliver Lodge.

In the second part, the dimensions and other details of construction of various instruments are described, such as an induction coil, aerial, condensers and inductances. The instruments manufactured by the author are described, but are not put forward too prominently.

The principal circuits for transmitting and receiving are given, with the reasons why some are superior to others.

The use of frame and coil aeriels, and of wires on the ground, telephone wires and lighting cables as substitutes, is described.

The author gives particulars of distances over which he has himself worked the sets described, and includes hints for the care and maintenance of the apparatus. The reception of continuous waves by the tikker and heterodyne methods, and the construction of a three-valve resistance amplifier, are described.

The third part is devoted to the Morse alphabet, service abbreviations, call signs of certain well-known stations. By a strange mistake (perhaps a printer's error) the S.O.S. distress signal is placed in a list of abbreviations used "by the British Post Office and the Marconi Company."

A description is given of the time and weather reports and the regulations of the French public radiotelegraphic service.

The diagrams are clearly drawn, the work is well written, and is suitable for an amateur who is beginning the study of wireless telegraphy and has not advanced to the stage of wanting to know "the reason why" of the various phenomena he encounters.

W. H. NOTTAGE.

3 X

INTRODUCTION À LA THÉORIE DES COURANTS TÉLÉPHONIQUES ET DE LA
RADIOTÉLÉGRAPHIE. By J. B. Pomey, with a Preface by A. Blondel.
(Paris: *Gauthier-Villars et Cie.* 1920. Pp. xiv + 510. Price
50 frs.)

M. Pomey is the chief telegraph engineer in the French Government service and this book is based on a course of lectures given by him to the students of the Senior Telegraph School.

Its primary object is therefore to present to such students the mathematical side of their work in order to give them an insight into the principles involved, though in many cases it is carried further than this and incorporates ideas developed by the author as a result of his own personal researches.

Only the latter half of the book deals with radiotelegraphy, the earlier part consisting entirely of the study of principles and their application to the standard problems of ordinary long distance telephony. The book commences with an introductory mathematical chapter dealing chiefly with the vector calculus necessary for the treatment of the theory which follows. The tendency of all modern mathematical physics is towards the employment of this calculus, which without doubt represents a great advance both in brevity and clearness on the old analytical methods. Unfortunately, however, but few physicists and still fewer engineers can use its method with facility; it is a subject which even in its more elementary forms has been neglected both in literature and teaching.

In this country at any rate there are very few except pure mathematicians and physicists who have a working acquaintance with three dimensional analysis on which of course such a calculus must be founded. Its chief use in this book is to prove the fundamental theorems in the three following chapters; as the problems discussed in the later ones do not in general possess more than two degrees of freedom, so that any one whose mathematical knowledge is not up to vector calculus may yet obtain a great deal of information from the later, and more practical part, of the book.

Chapters II., III. and IV. are devoted to a discussion of the fundamental theorems of electromagnetism, and though they are probably beyond the depth of the average student they contain some of the most interesting work in the book, due to the researches of the author, and to his predecessor M. Vaschy. Broadly speaking one of the leading ideas of the system is to take as the fundamental datum the idea of force, and to deduce from it the ordinary ideas of charges, etc. by a mathematical operation. For instance the charge Q on a body is defined as the integral of a vector over a surface.

Theoretically no doubt this is perfectly sound; in any science resting on a strictly logical basis it is permissible to define the fundamental principle at the most convenient point of the chain and the sequence is bound to be complete. In this way mathematical simplification can often be obtained; but it is a method which offers great difficulties to students and to many engineers. For such people the most convincing point at which to start is with an idea which appears in direct presentation or can be reached by simple analogy. It may be argued that in truth the fundamental physical presentation is that of force, but to see this requires a power of abstraction which is often not present; and tends to the less trained mind to give an idea of complexity which is not really justified. Once however, the fundamentals have been defined in this manner, they are used in subsequent investigations in a way in which they are intelligible to those who are familiar with the more usual definition. Chapter III. deals with the laws of Ohm and Laplace, and the law of induction; special attention being paid to the last in view of the methods of definition employed in the book. The theories of Maxwell and Lorenz are then dealt with. Here not so much attention is paid to the purely mathematical side; the object is rather to bring the older theories, such as the two-fluid theory and Maxwell's displacement current into line with the more modern theories of the electric field.

It is well known that modern research has profoundly modified many of the physical theories on which the earlier mathematicians based their investigations, consequently the validity and interpretation of their results is bound up with the question of how far their

physical ideas can still be considered to hold, and what new interpretation must be placed on them.

The question of the energy of the electric field is discussed and the fact that it is possible to show from the law of induction an analogy with the mechanical principle of conservation of energy; and it is suggested that, as in mechanics, this should be taken as the fundamental datum.

With Chapter V. commences the more practical part of the book. A few pages are given to the consideration of simple harmonic functions both by the use of imaginaries and by the vector calculus. Preference is given to the latter owing to an ambiguity of sign which occurs when the former is applied to the more complex problems.

Damped oscillations are treated by means of a rotating vector tracing out a spiral, and oscillating circuits in general are treated by analogy with the corresponding mechanical problems such as the moving coil galvanometer, special attention being paid to the case in which an oscillating circuit receives periodic impulses.

The equation for the logarithmic decrement is derived in the ordinary way, and then by means of a series of curves derived from it the effect on it is shown graphically for variations of L , C and R respectively the other two being kept constant. Such curves would perhaps be more useful, for wireless purposes, at any rate, if the wavelength (and hence the period) had been the constant quantity. A short chapter is devoted to networks, and then a general investigation of the power, both actual and wattless, in such networks is undertaken by means of the vector calculus. The results are interesting theoretically but in the general form are rather elaborate and heavy for practical application.

Chapters XI. and XII. are devoted to a very full development of the work of Pupin on which of course the loading of modern telephone lines is based, and to its application; showing how all the necessary determinations can be made in any particular case.

Chapter XIV. treats in full what is often known as the telegraph equation; the law of propagation of a current along a finite cable under various different terminal conditions, which is solved mathematically. It is then shown that the same results can be obtained in another way, by representing the line as a series of circuits forming a network, and by then indefinitely increasing this number. In this way a great deal of calculus can be avoided.

The consideration of radiotelegraphy proper does not commence until Chapter XV. which is devoted to the question of the mechanical problem of the aerial wire and involves the ordinary catenary equations; the latter part dealing with the strength of the supporting masts.

The electrical constants of the aerial are treated by direct analogy with the vibrating string the equations of which are derived by means of Lagrange's equations and which are then converted directly to the electrical problem by changing the names of the quantities involved. Attention is drawn to the point, so often neglected that the loading of an aerial by an inductance at one end really causes a discontinuity in the constants so that reflections occur and the oscillation is no longer pure and simple.

After a discussion on the resonance of the primary circuit of a transmitter the theory of the spark discharge, the high frequency alternator and the Duddell arc is considered; but the thermionic valve is not dealt with.

The final chapters are devoted to the solution of the problems dealing with the theory and measurement of capacity and self-induction. The book is an excellent attempt to solve the almost impossible problem of presenting to the practical man the fundamental theory of his subject, but the crucial point arises as usual over the mathematics. For instance Lagrange's equations are a *terra incognita* to the majority of such people, and anybody who was not thoroughly familiar with the calculus would find himself baffled very quickly, though no doubt when given as lectures many points were enlarged upon in a manner which it is not possible to reproduce in print and in this way many such difficulties were bridged.

In the general arrangement of the book a most excellent plan which ought to be widely copied is the giving at the commencement of each chapter a short summary of the problems which will be discussed in it in detail.

J. HOLLINGWORTH.

WORKING DIAGRAM OF VALVE AMPLIFYING RECEIVER CIRCUITS. H. W. Sullivan. (London: *H. W. Sullivan*. 1920. Pp. 24. Price 1s.)

The working diagrams inserted in this booklet have been selected for their simplicity, and easy application to practical working. They are intended chiefly for use in conjunction with the catalogue of wireless instruments issued by the same firm, and with this in view, the parts of the diagrams have been numbered to correspond with the numbering adopted in the catalogue. The diagrams seem to be well chosen, and should be useful both for amateurs and experimenters, and in college and similar laboratories.

P. R. C.

Books Received.

ELECTRON TUBES—Langmuir's Record in *Arnold v. Langmuir*. (Interference No. 40,380 in the U.S. Patent Office. 1920. Pp. 969.)

This highly interesting volume contains a very detailed account of the action of thermionic devices as given in evidence by Langmuir and his assistants at the General Electric Company at Schenectady.

ELEMENTS OF RADIO TELEGRAPHY. By E. W. Stone, M.Inst.R.E. (New York: *D. Van Nostrand Co.* London: *Crosby Lockwood & Son*. 1920. Pp. vii + 267. Price 16s. 6d. net.)

VOCABULAIRE EN CINQ LANGUES. By H. Viard. (Paris: *Gautier Villars et Cie*. 1920. Pp. x + 108. Price 7 fr. 50.)

Correspondence.

TRIODE VALVE DESIGN.

To the Editor of the RADIO REVIEW.

SIR,—In the review of a paper "The Development of Thermionic Valves for Naval Uses," by B. S. Gossling, in the August RADIO REVIEW, the formula

$$m = \frac{\pi N d' \log (d/d')}{\log (1/\pi N d_g)}$$

is given for the amplification factor of a cylindrical valve. If this result is differentiated with respect to d' and $\partial m/\partial d'$ equated to zero, the result obtained is $\log d/d' = 1$, or $d/d' = e = 2.72$.

Therefore if d , d_g and N are fixed m has a stationary value and is a maximum when $d/d' = 2.72$.

Hence, in designing valves there is some advantage in making $d/d' = 2.72$, for with such a value variations of m due to slight errors in d/d' caused by inaccurate centring of the filament and errors in d and d' themselves, will be minimised. It is interesting to note that many types of receiving valves fulfil this condition very closely.

A. C. BARTLETT.

Research Laboratories of the General Electric Co., Ltd.,
London,

October 5th, 1920.